



Cartridge Valves Technical Information

Cavities

Quick reference

AVAILABLE CAVITIES

Cavity	Page
SDC08-2	20.3
SDC08-3	20.4
SDC08-4	20.5
SDC10-2	20.6
SDC10-3	20.7
SDC10-3S	20.8
SDC10-4	20.9
SDC12-2	20.10
SDC12-3	20.11
SDC16-2	20.12
SDC16-3	20.13
SDC16-3S	20.14
SDC20-2	20.15
SDC20-3	20.16
SDC20-4	20.17
CP04-2	20.18
CP04-3	20.19
CP07-3	20.20
CP08-3L	20.21
CP12-2	20.22
CP12-3	20.23
CP12-3M	20.24
CP12-3S	20.25
CP12-4	20.26
CP16-4	20.27
CP20-3S	20.28
NCS04/2	20.29
NCS04/3	20.30
NCS06/2	20.31
NCS06/3	20.32
NCS06/4	20.33
NCS12/2	20.34
NCS12/3	20.35
NCS12/4	20.36
VME06	20.37
VME07	20.38
VME08	20.39
FC-144	20.40
FC-304	20.41
FC-336	20.42
ISO D03	20.43
ISO D05	20.44



Cartridge Valves Technical Information

Cavities

Application notes

OVERVIEW

The following pages show details for Sauer-Danfoss standard valve cavities. These cavities are designed around SAE standard O-ring thread ports. In many cases these cavities are interchangeable with cavities used by other manufacturers. The table below is intended as a guide for cartridge valve interchanges.

Cavity crossover table

Sauer-Danfoss	Thread	Delta Power	Eaton-Vickers	HydraForce	Parker	Sterling
CP04-2	7/16-20			NO	NO	
CP04-3				NO	NO	
CP07-3	5/8-18	YES		YES	YES	
SDC08-2	3/4-16	YES	YES	YES	YES	YES
CP08-3		YES	YES	YES	YES	YES
CP08-3L						
SDC08-4		YES	YES	YES	YES	YES
SDC10-2	7/8-14	YES	YES	YES	YES	YES
SDC10-3		YES	YES	YES	YES	YES
SDC10-3S			YES	YES	YES	YES
SDC10-4		YES	YES	YES	YES	YES
CP12-2	1 1/16-12	NO	NO	YES	NO	
SDC12-2		NO	NO	NO	NO	
CP12-3S		NO	NO	NO	NO	
CP12-3		NO	NO	YES	NO	
CP12-4		NO	NO	NO	NO	
SDC16-2	1 5/16-12		YES	YES	YES	YES
SDC16-3S			YES	YES	YES	YES
SDC16-3			YES	YES	YES	YES
SDC16-4			YES	YES	YES	YES
SDC20-2	1 5/8-12		YES		YES	
CP20-3S				NO		
SDC20-3				YES		
SDC20-4				YES		

Please note that most manufacturers have many non-standard cavities and that details are subject to change. Compare cavity details before interchanging cartridges.

The National Fluid Power Association (NFPA) and International Standards Organization (ISO) are developing a standard, NFPA T3.5.31M-19XX, that will define an industry-wide set of standard cavities. Sauer-Danfoss will manufacture cartridge valves for NFPA cavities upon formal approval of the standard.



Cartridge Valves Technical Information

Cavities

SDC08-2

Dimensions

mm [in]

TOLERANCES UNLESS OTHERWISE SPECIFIED

Diameter and Lengths:
if < 18mm ± 0.1 [0.004]
Angles ± 2°



\varnothing	0.05 [0.002]	A
\perp	0.025 [0.001]	B

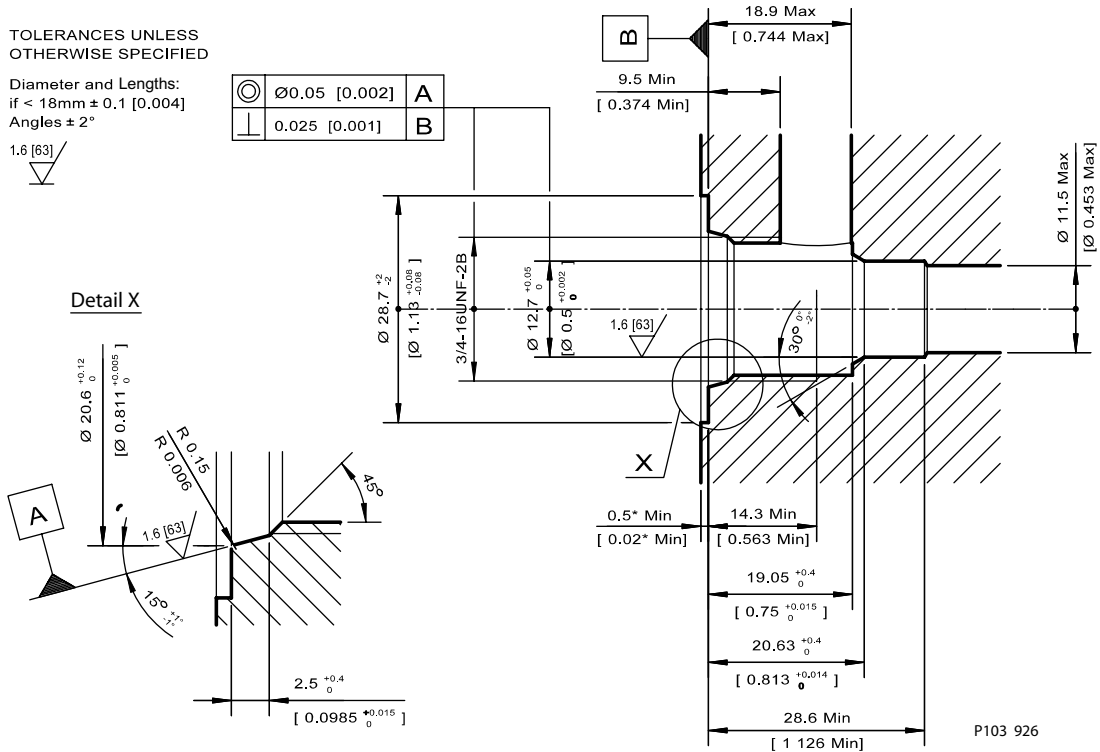

Form tools

High speed steel tool	9539914
Diamond cutting tool	9539924

Housings

Order Code	Description	Ports	Page
CP08-2-4S	Aluminum Housing	SAE #4	20.66
CP08-2-6S	Aluminum Housing	SAE #6	20.66
CP08-2-6S-2CR	Aluminum Housing - Crossover	SAE #6	20.65
CP08-2-8S-2CR	Aluminum Housing - Crossover	SAE #8	20.65
CP08-2-8S-2PL	Aluminum Housing - Parallel	SAE #8	20.61
CP08-2-S4S	Steel Housing	SAE #4	20.66
SDC08-2-HG1-3B	Aluminum Housing, Two #2 Ports	3/8 BSP	20.62
SDC08-2-HG2-3B	Aluminum Housing, Two #1 Ports	3/8 BSP	20.63
SDC08-2-HG-2B	Aluminum Housing	1/4 BSP	20.64
SDC08-2-HG-3B	Aluminum Housing	3/8 BSP	20.64



Cartridge Valves Technical Information

Cavities

SDC08-3

Dimensions

mm [in]

TOLERANCES UNLESS OTHERWISE SPECIFIED

Diameter and Lengths:
if < 18mm ± 0.1 [0.004]
Angles ± 2°



⊙	∅0.05 [0.002]	A
⊥	0.025 [0.001]	B

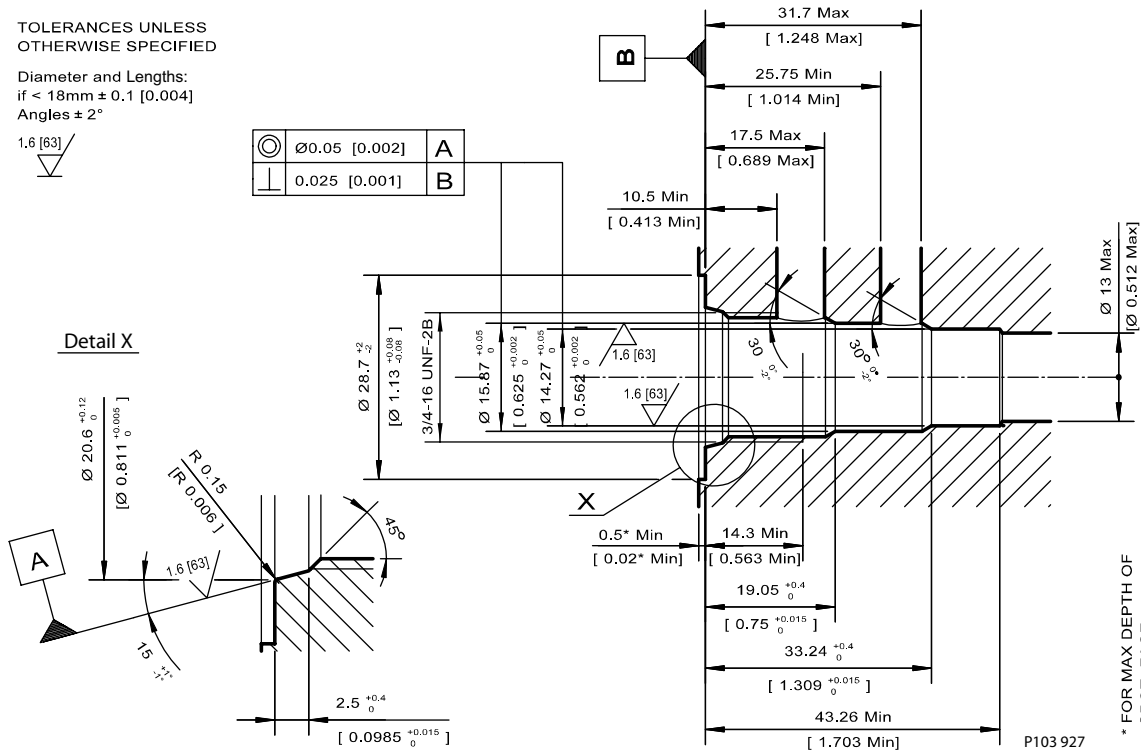

Form tools

High speed steel tool	9540014
Diamond cutting tool	9540024

Housings

Order Code	Description	Ports	Page
CP08-3-4S	Aluminum Housing	SAE #4	20.69
CP08-3-6S	Aluminum Housing	SAE #6	20.69
CP08-3-S4S	Steel Housing	SAE #4	20.69
CP08-3-S6S	Steel Housing	SAE #6	20.69
SDC08-3-HI-2B	Aluminum Housing, Two #1 Ports	1/4 BSP	20.67
SDC08-3-SE-2B	Aluminum Housing	1/4 BSP	20.68
SDC08-3-SE-3B	Aluminum Housing	3/8 BSP	20.68



Cartridge Valves Technical Information

Cavities

SDC08-4

Dimensions

mm [in]

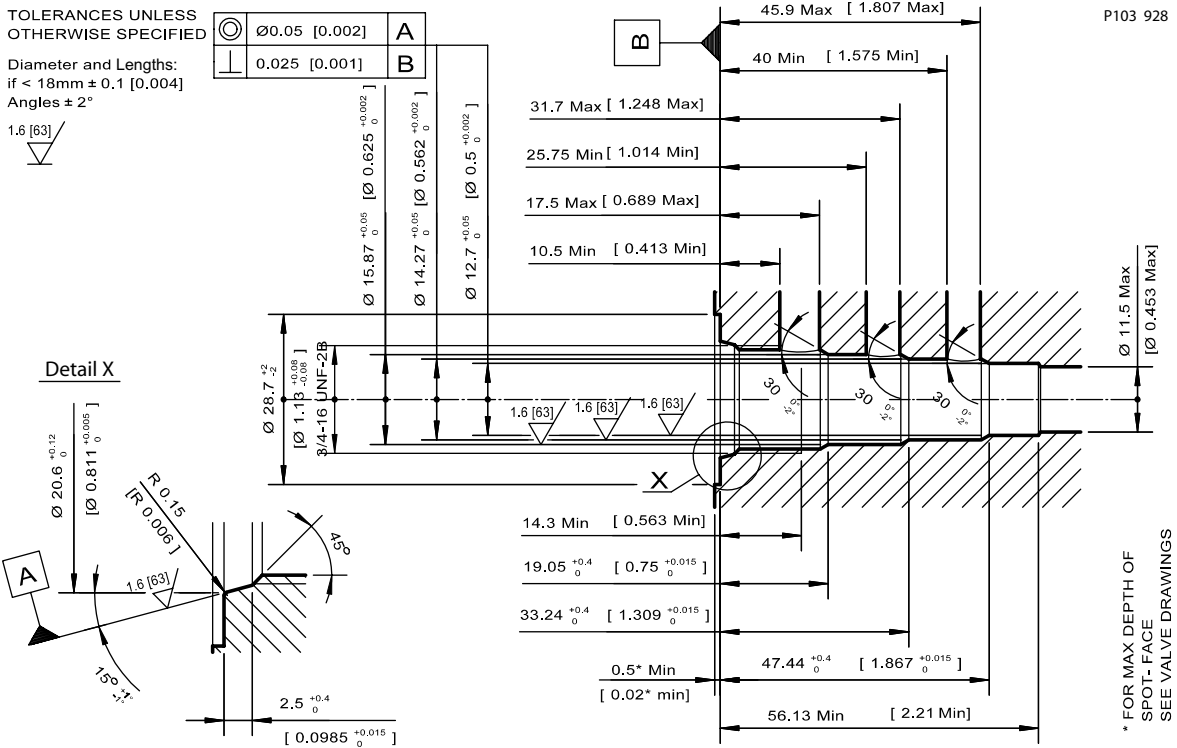

Form tools

High speed steel tool	9540114
Diamond cutting tool	9540124

Housings

Order Code	Description	Ports	Page
CP08-4-4S	Aluminum Housing	SAE #4	20.70
CP08-4-6S	Aluminum Housing	SAE #6	20.70
SDC08-4-L-2B	Aluminum Housing	1/4 BSP	20.71



Cartridge Valves Technical Information

Cavities

SDC10-2

Dimensions

mm [in]

TOLERANCES UNLESS OTHERWISE SPECIFIED

Diameter and Lengths:
if < 18mm ± 0.1 [0.004]
Angles ± 2°



	Ø0.05 [0.002]	A
	0.025 [0.001]	B

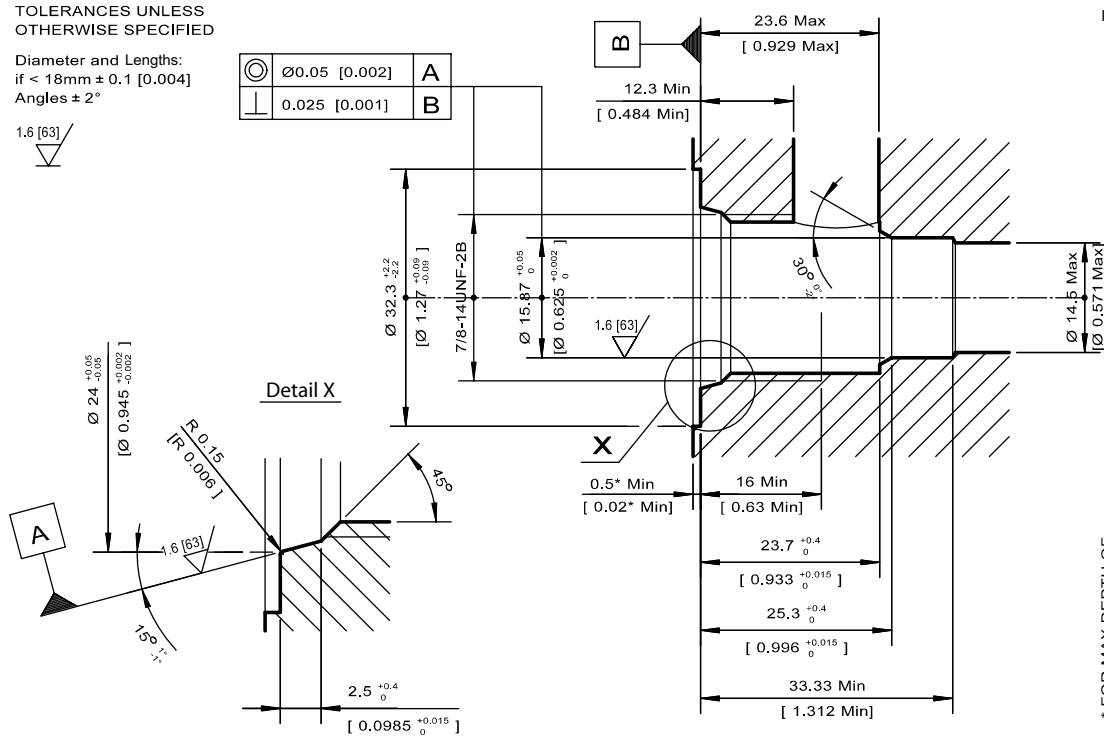

P103 929

* FOR MAX DEPTH OF SPOT-FACE SEE VALVE DRAWINGS

Form tools

High speed steel tool	9540214
Diamond cutting tool	9540224

Housings

Order Code	Description	Ports	Page
CP10-2-10S-2CR	Aluminum Housing	SAE #10	20.74
CP10-2-6S	Aluminum Housing	SAE #6	20.75
CP10-2-8S	Aluminum Housing	SAE #8	20.75
CP10-2-8S-2PL	Parallel housing	SAE #8	20.72
CP10-2-S6S	Steel Housing	SAE #6	20.75
CP10-2-S8S	Steel Housing	SAE #8	20.75
SDC10-2-DG-3B	Aluminum Housing	3/8 BSP	20.77
SDC10-2-DG-4B	Aluminum Housing	1/2 BSP	20.73
SDC10-2-LG1-4B	Aluminum Housing, Two #2 Ports	1/2 BSP	20.76
SDC10-2-LG2-4B	Aluminum Housing, Two #1 Ports	1/2 BSP	20.78



Cartridge Valves Technical Information

Cavities

SDC10-3

Dimensions

mm [in]

TOLERANCES UNLESS OTHERWISE SPECIFIED

Diameter and Lengths:
if < 18mm ± 0.1 [0.004]
Angles ± 2°



	Ø0.05 [0.002]	A
	0.025 [0.001]	B

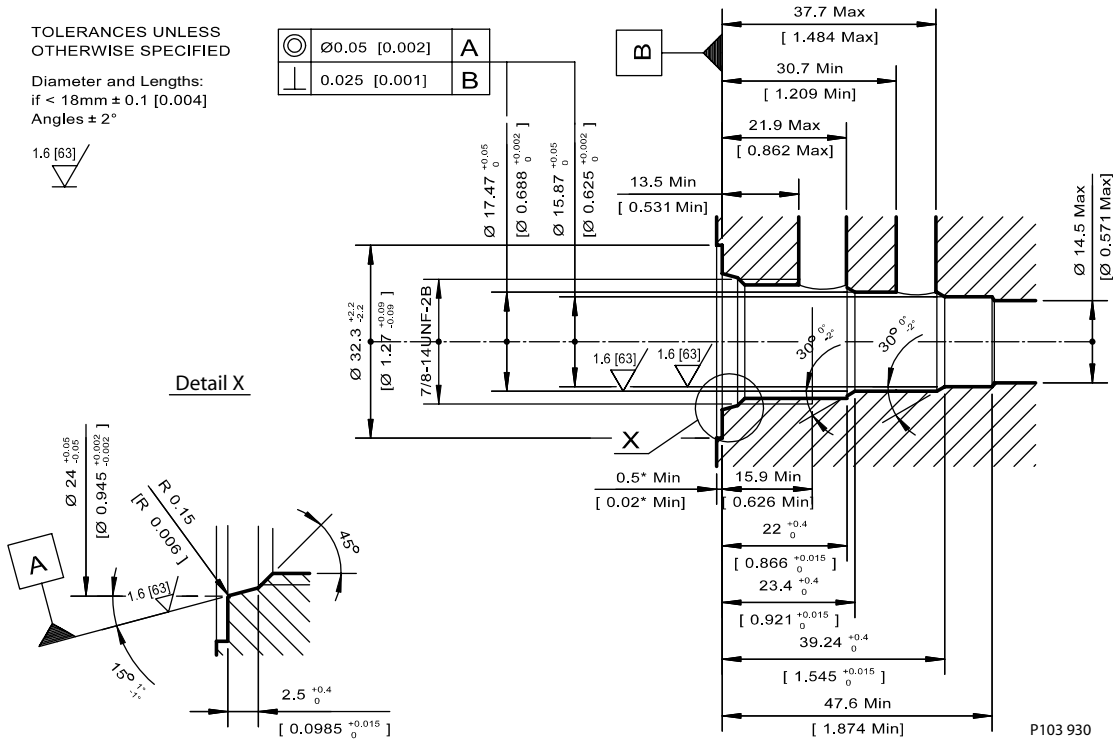

Form tools

High speed steel tool	9540314
Diamond cutting tool	9540324

Housings

Order Code	Description	Ports	Page
CP10-3-6S	Aluminum Housing	SAE #6	20.79
CP10-3-8S	Aluminum Housing	SAE #8	20.79
CP10-3-S6S	Steel Housing	SAE #6	20.79
CP10-3-S8S	Steel Housing	SAE #8	20.79
SDC10-3-SE-3B	Aluminum Housing	3/8 BSP	20.83
SDC10-3-SE-4B	Aluminum Housing	1/2 BSP	20.82
SDC10-3-SI-3B	Aluminum Housing, Two #1 Ports	3/8 BSP	20.80
SDC10-3-SI-4B	Aluminum Housing, Two #1 Ports	1/2 BSP	20.81



Cartridge Valves Technical Information

Cavities

SDC10-3S

Dimensions

mm [in]

TOLERANCES UNLESS OTHERWISE SPECIFIED

⊙	Ø0.05 [0.002]	A
⊥	0.025 [0.001]	B

Diameter and Lengths:
if < 18mm ± 0.1 [0.004]
Angles ± 2°



Particular X

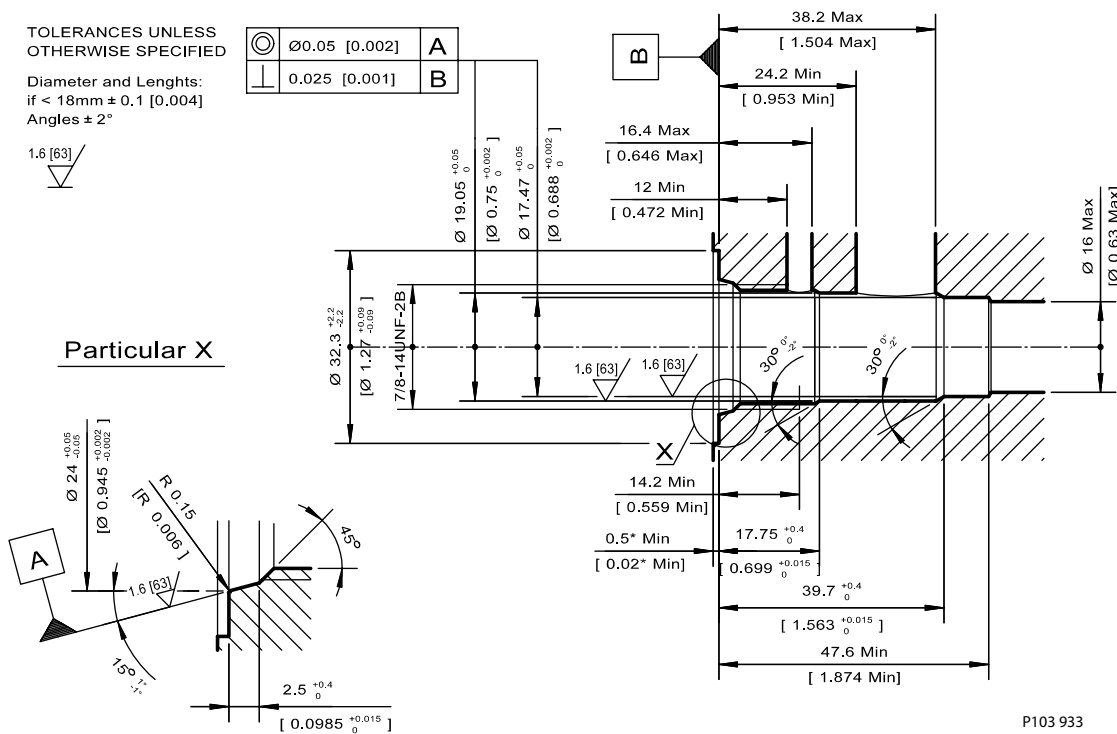

P103 933

* FOR MAX DEPTH OF SPOT-FACE SEE VALVE DRAWINGS

Form tools

High speed steel tool	9540514
Diamond cutting tool	9540524

Housings

Order Code	Description	Ports	Page
SDC10-3S-10S/6S	Aluminum Housing, Pilot at Port #3	SAE #10	20.85
SDC10-3S-8S/6S	Aluminum Housing, Pilot at Port #3	SAE #8	20.85
SDC10-3S-SE-3B	Aluminum Housing	3/8 BSP	20.84
SDC10-3S-SE-4B	Aluminum Housing	1/2 BSP	20.84
SDC10-3S-6S/6S	Aluminum housing, pilot at port #3	SAE #6	20.85



Cartridge Valves Technical Information

Cavities

SDC10-4

Dimensions

mm [in]

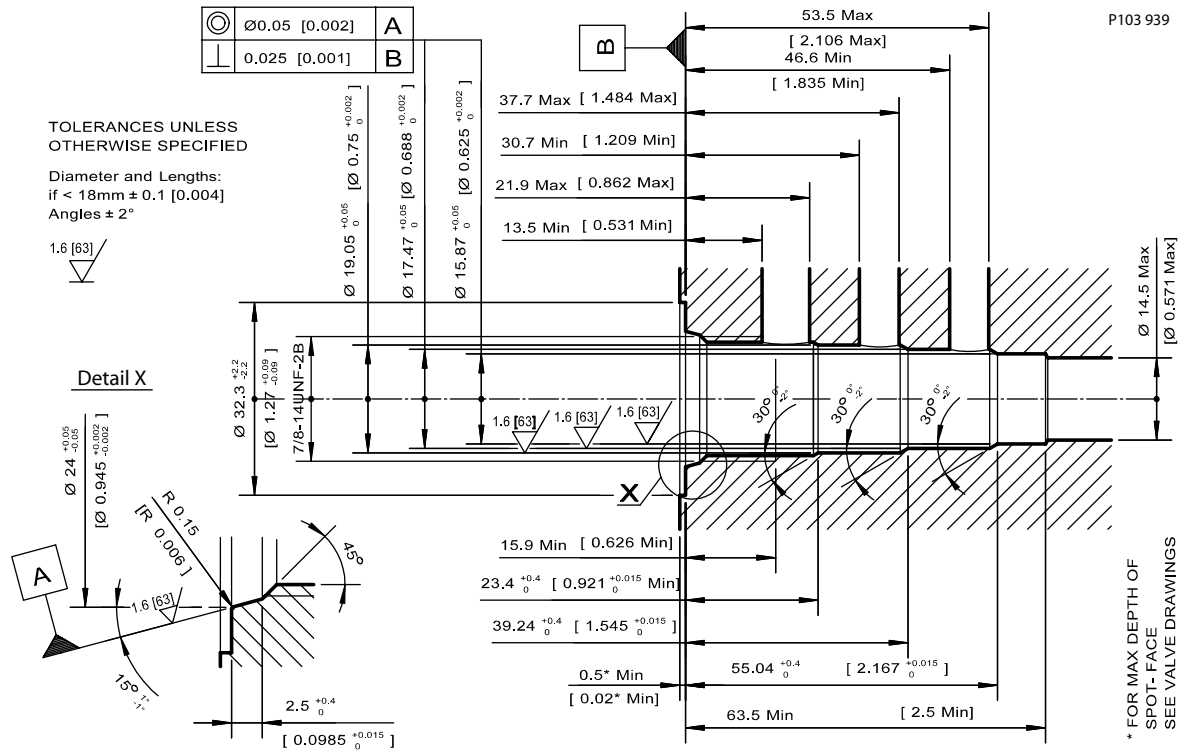

Form tools

High speed steel tool	9540414
Diamond cutting tool	9540424

Housings

Order Code	Description	Ports	Page
CP10-4-6S	Aluminum Housing	SAE #6	20.86
CP10-4-6S-X1	Aluminum Housing, No Port #1	SAE #6	20.86
CP10-4-8S	Aluminum Housing	SAE #8	20.86
CP10-4-8S-X1	Aluminum Housing, No Port #1	SAE #8	20.86
CP10-4-S6S	Steel Housing	SAE #6	20.86
CP10-4-S8S	Steel Housing	SAE #8	20.86
SDC10-4-HD-3B	Aluminum Housing, No Port #1	3/8 BSP	20.87
SDC10-4-L-3B	Aluminum Housing	3/8 BSP	20.88
SDC10-4-L-4B	Aluminum Housing	1/2 BSP	20.89



Cartridge Valves Technical Information

Cavities

SDC12-2

Dimensions

mm [in]

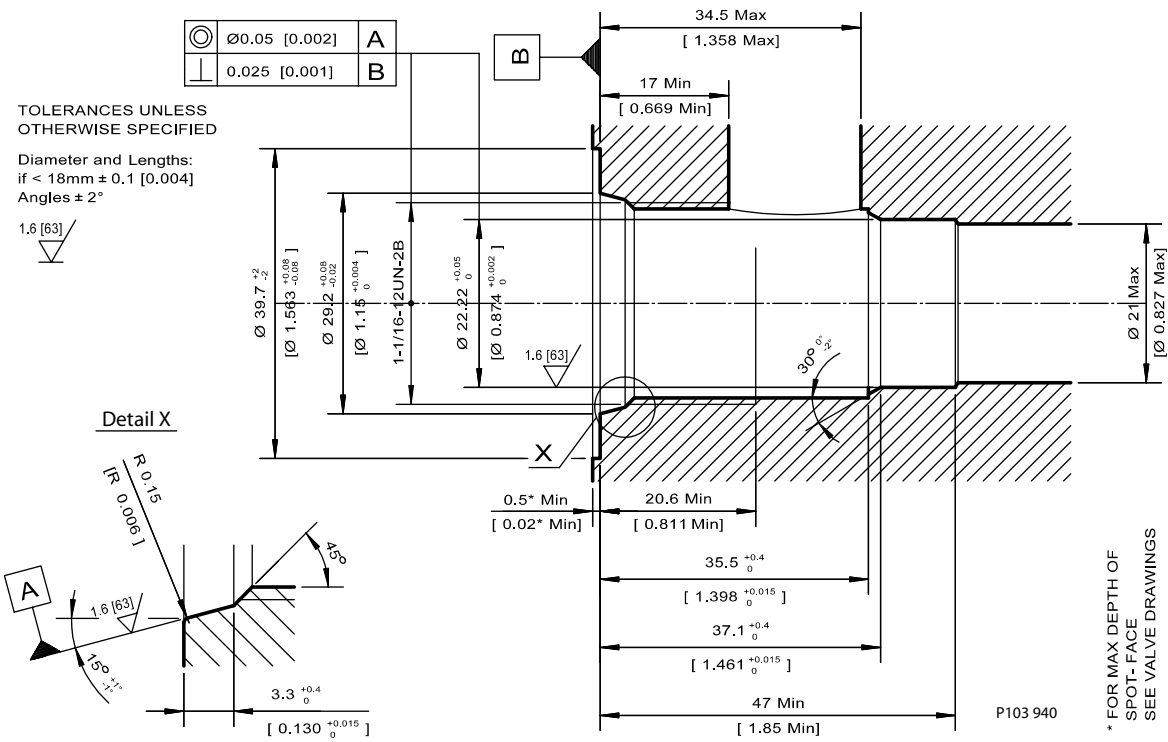

Caution
SDC12-2 and CP12-2 cavities are not interchangeable. Differences in sealing area depth may lead to leakage if the wrong valve is used with this cavity. Use only the specified cavity for each valve.

Form tools

High speed steel tool	9540914
Diamond cutting tool	9540924

Housings

Order Code	Description	Ports	Page
SDC12-2-DG-4B	Aluminum Housing	1/2 BSP	20.94
SDC12-2-DG-6B	Aluminum Housing	3/4 BSP	20.90
SDC12-2-LG1-6B	Aluminum Housing, Two #2 Ports	3/4 BSP	20.93
SDC12-2-LG2-6B	Aluminum Housing, Two #1 Ports	3/4 BSP	20.92
SDC12-2-10S	Aluminum housing	#10 SAE	20.91
SDC12-2-12S	Aluminum housing	#12 SAE	20.91

Cavities SDC12-2



Cartridge Valves Technical Information
Cavities
SDC12-3

Dimensions

mm [in]

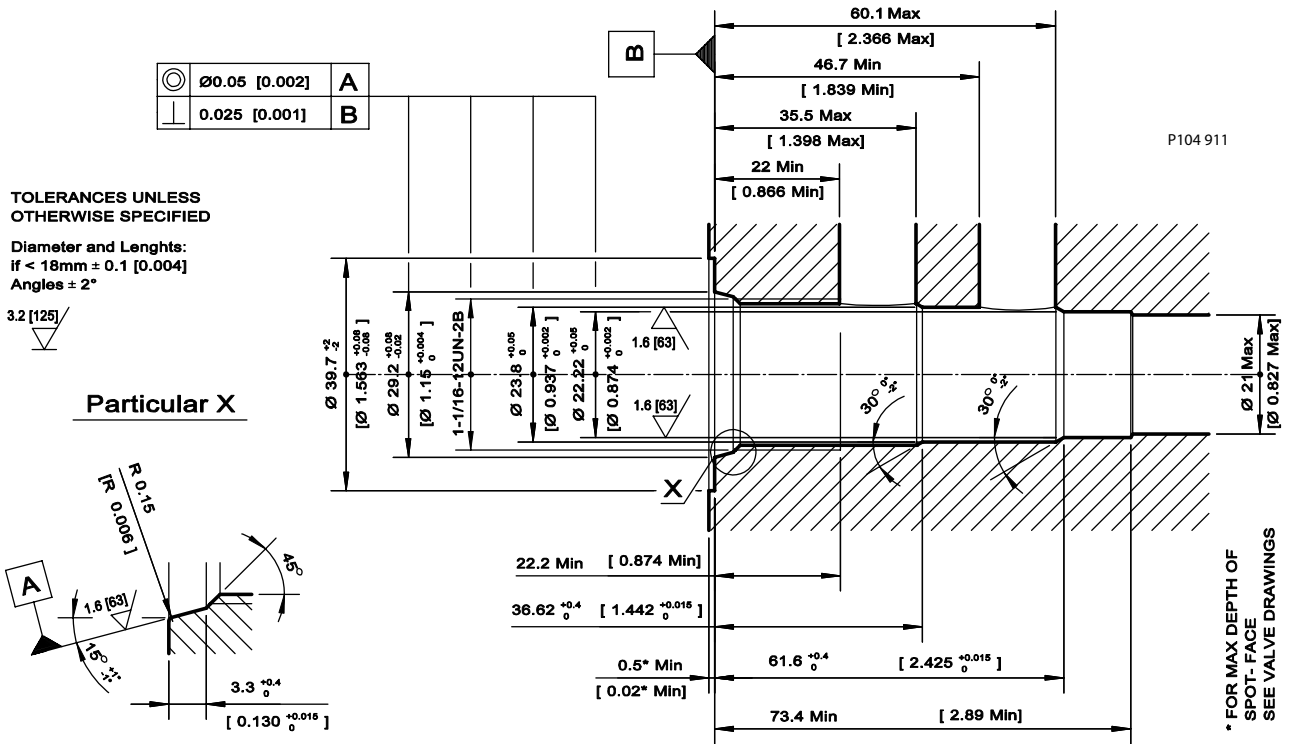

Form tools

Roughing tool	Consult Factory
Finishing tool	Consult Factory
Tap	Consult Factory

Cavities SDC12-3



Cartridge Valves Technical Information
Cavities
SDC16-3

Dimensions

mm [in]

TOLERANCES UNLESS OTHERWISE SPECIFIED

Diameter and Lengths:
if < 18mm ± 0.1 [0.004]
Angles ± 2°

1.6 [63]

⊙	∅0.05 [0.002]	A
⊥	0.025 [0.001]	B

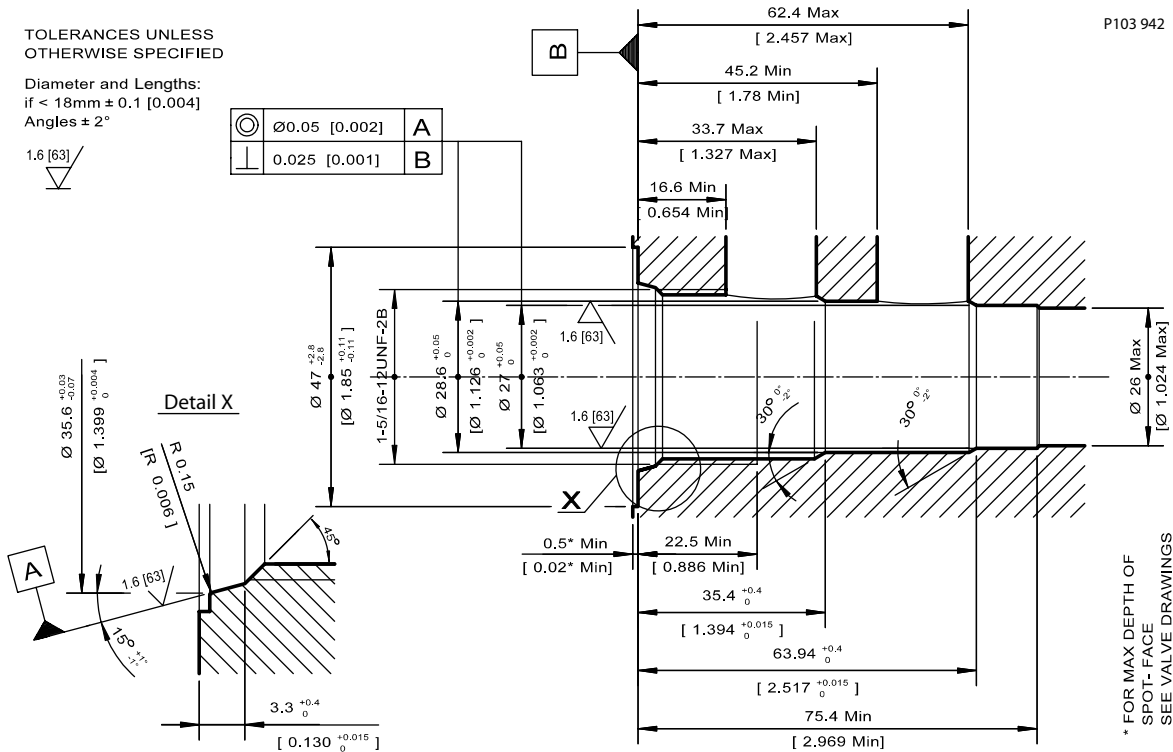

Form tools

High speed steel tool	9541514
Diamond cutting tool	9541524

Housings

Order Code	Description	Ports	Page
CP16-3-12S	Aluminum Housing	SAE #12	20.103
CP16-3-16S	Aluminum Housing	SAE #16	20.103
SDC16-2-HE-6B	Aluminum Housing	3/4 BSP	20.101
SDC16-2-HE-8B	Aluminum Housing	1 BSP	20.100
SDC16-3-HI-8B	Aluminum Housing, Two #1 Ports	1 BSP	20.102



Cartridge Valves Technical Information

Cavities

SDC16-3S

Dimensions

mm [in]

TOLERANCES UNLESS OTHERWISE SPECIFIED

Diameter and Lengths:
if < 18mm ± 0.1 [0.004]
Angles ± 2°



⊙	∅0.05 [0.002]	A
⊥	0.025 [0.001]	B

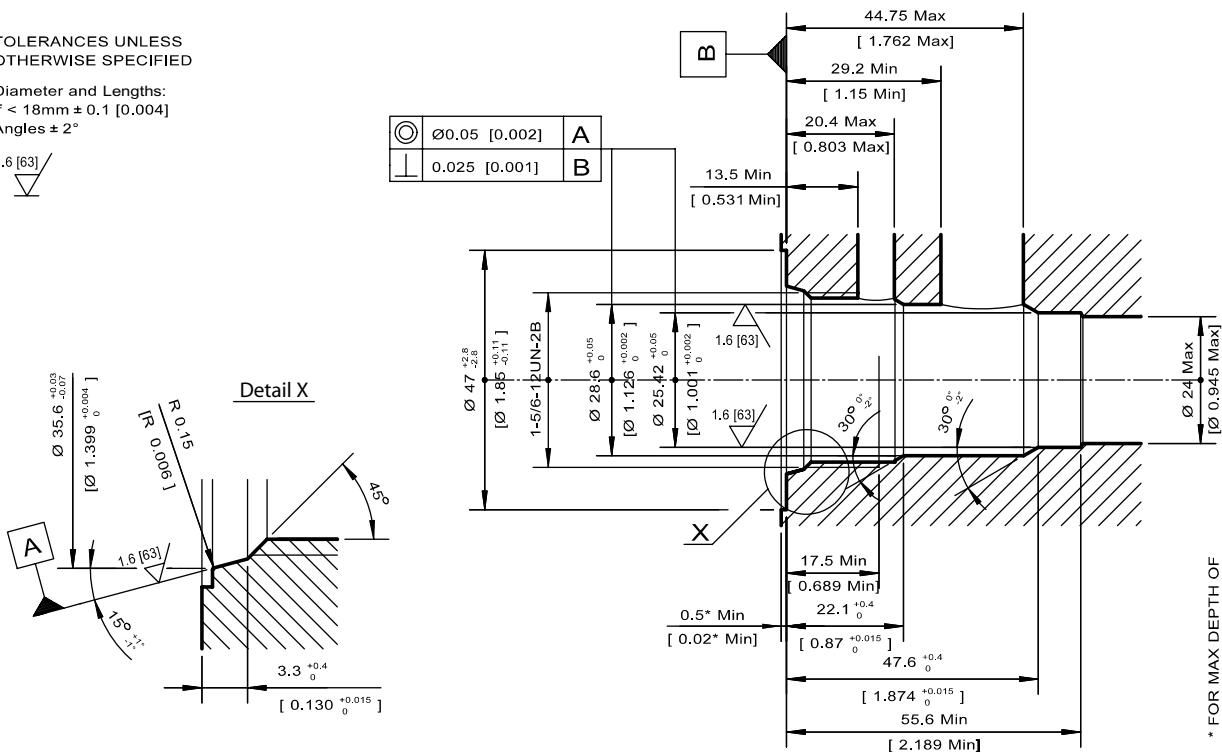

* FOR MAX DEPTH OF SPOT-FACE SEE VALVE DRAWINGS

P103 943

Form tools

High speed steel tool	9541414
Diamond cutting tool	9541424

Housings

Order Code	Description	Ports	Page
CP16-3S-12S/4S	Aluminum Housing, Pilot at Port #3	SAE #12, #4	20.104
CP16-3S-16S/4S	Aluminum Housing, Pilot at Port #3	SAE #16, #4	20.104
CP16-3S-6B/2B	Aluminum Housing, Pilot at Port #3	3/4 BSP, 1/4 BSP	20.104
CP16-3S-8B/2B	Aluminum Housing, Pilot at Port #3	1 BSP, 1/4 BSP	20.104



Cartridge Valves Technical Information
Cavities
SDC20-2

Dimensions

mm [in]

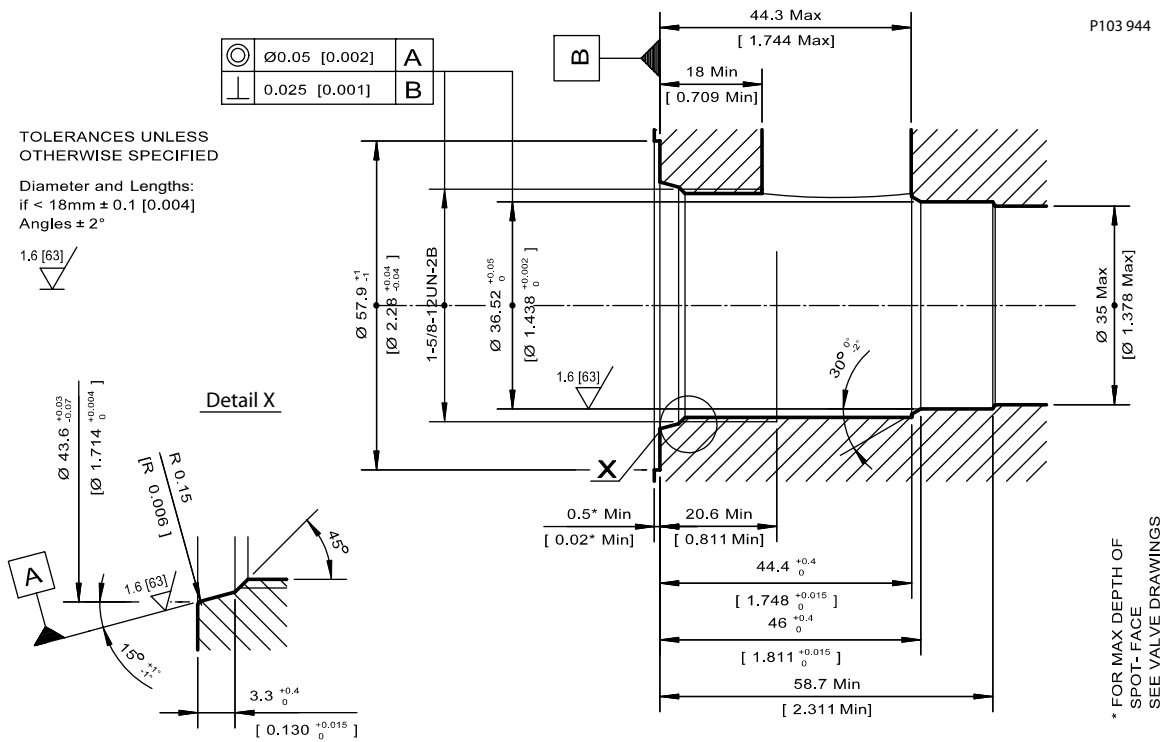

Form tools

High speed steel tool	9541714
Diamond cutting tool	9541724

Housings

Order Code	Description	Ports	Page
CP20-2-10B	Aluminum Housing	1 1/4 BSP	20.105
CP20-2-16S	Aluminum Housing	SAE #16	20.105
CP20-2-20S	Aluminum Housing	SAE #20	20.105
CP20-2-8B	Aluminum Housing	1 BSP	20.105

Cavities
SDC20-2



Cartridge Valves Technical Information

Cavities

SDC20-3

Dimensions

mm [in]

TOLERANCES UNLESS OTHERWISE SPECIFIED

Diameter and Lengths:
if < 18mm ± 0.1 [0.004]
Angles ± 2°



⊙	∅0.05 [0.002]	A
⊥	0.025 [0.001]	B

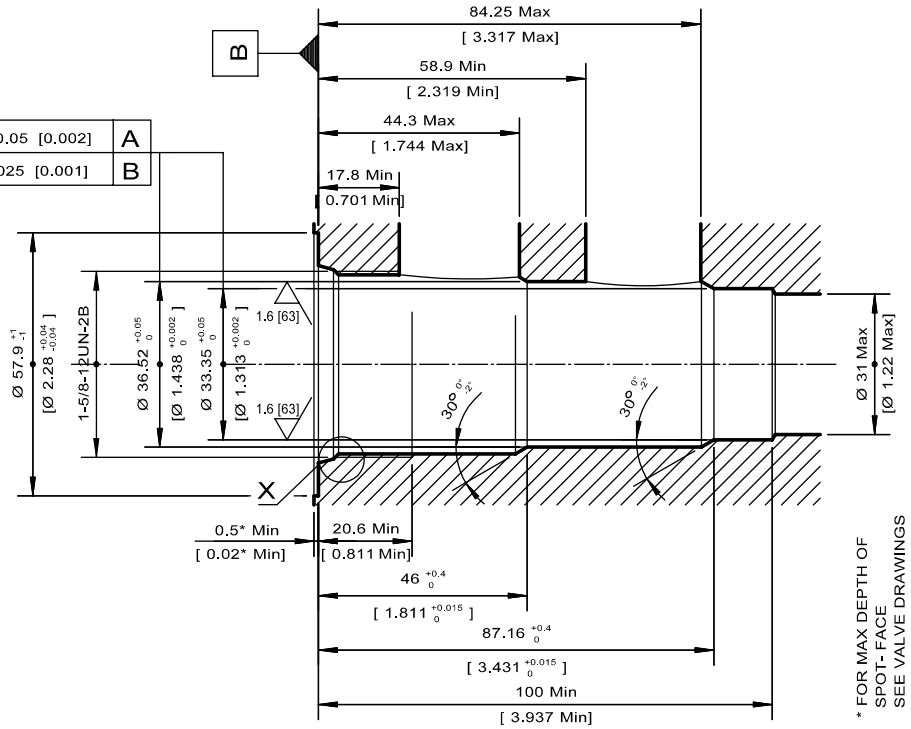
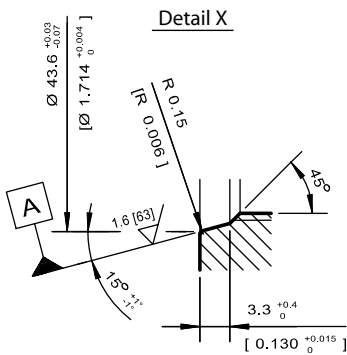

* FOR MAX DEPTH OF SPOT-FACE SEE VALVE DRAWINGS

P103 945

Form tools

High speed steel tool	9541914
Diamond cutting tool	9541924

Housings

Order Code	Description	Ports	Page
CP20-3-10B	Aluminum Housing	1 1/4 BSP	20.106
CP20-3-10B/2B1	Aluminum Housing, Pilot at Port #3	1 1/4 BSP, 1/4 BSP	20.106
CP20-3-16S	Aluminum Housing	SAE #16	20.106
CP20-3-16S/4S1	Aluminum Housing, Pilot at Port #3	SAE #16, #4	20.106
CP20-3-20S	Aluminum Housing	SAE #20	20.106
CP20-3-20S/4S1	Aluminum Housing, Pilot at Port #3	SAE #20, #4	20.106
CP20-3-8B	Aluminum Housing	1 BSP	20.106
CP20-3-8B/2B1	Aluminum Housing, Pilot at Port #3	1 BSP, 1/4 BSP	20.106



Cartridge Valves Technical Information

Cavities

SDC20-4

Dimensions

mm [in]

TOLERANCES UNLESS OTHERWISE SPECIFIED

Diameter and Lengths:
if < 18mm ± 0.1 [0.004]
Angles ± 2°



⌀	0.05 [0.002]	A
\perp	0.025 [0.001]	B

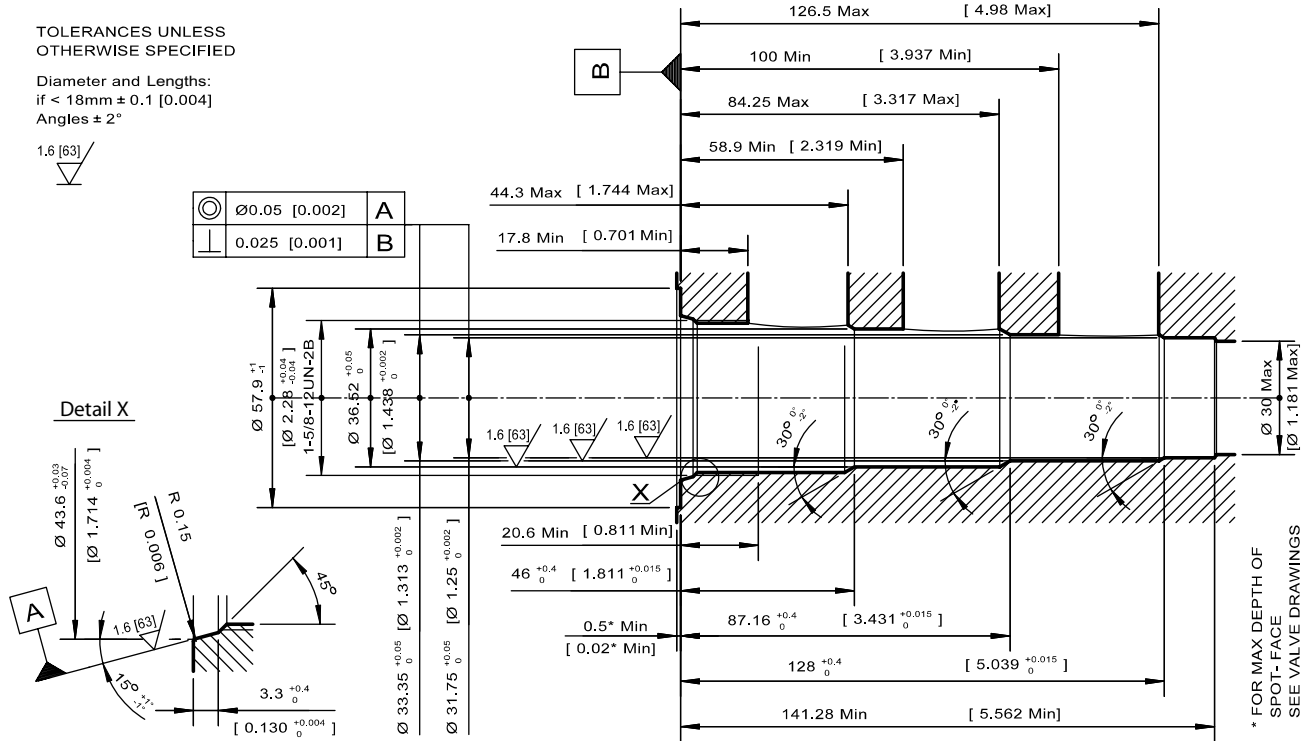

P103 946

Form tools

High speed steel tool	9542014
Diamond cutting tool	9542024

Housings

Order Code	Description	Ports	Page
CP20-4-10B	Aluminum Housing	1 1/4 BSP	20.107
CP20-4-10B-X1	Aluminum Housing, No Port #1	1 1/4 BSP	20.107
CP20-4-16S	Aluminum Housing	SAE #16	20.107
CP20-4-16S/4S	Aluminum Housing, Pilot at Port #1	SAE #16, #4	20.107
CP20-4-16S-X1	Aluminum Housing, No Port #1	SAE #16	20.107
CP20-4-20S	Aluminum Housing	SAE #20	20.107
CP20-4-20S/4S	Aluminum Housing, Pilot at Port #1	SAE #20, #4	20.107
CP20-4-20S-X1	Aluminum Housing, No Port #1	SAE #20	20.107
CP20-4-8B	Aluminum Housing	1 BSP	20.107
CP20-4-8B-X1	Aluminum Housing, No Port #1	1 BSP	20.107
CP20-4-516S	Steel Housing	SAE #16	20.107
CP20-4-516S-X1	Steel Housing, No Port #1	SAE #16	20.107

Cavities
SDC20-4



Cartridge Valves Technical Information
Cavities
CP04-2

Dimensions

mm [in]

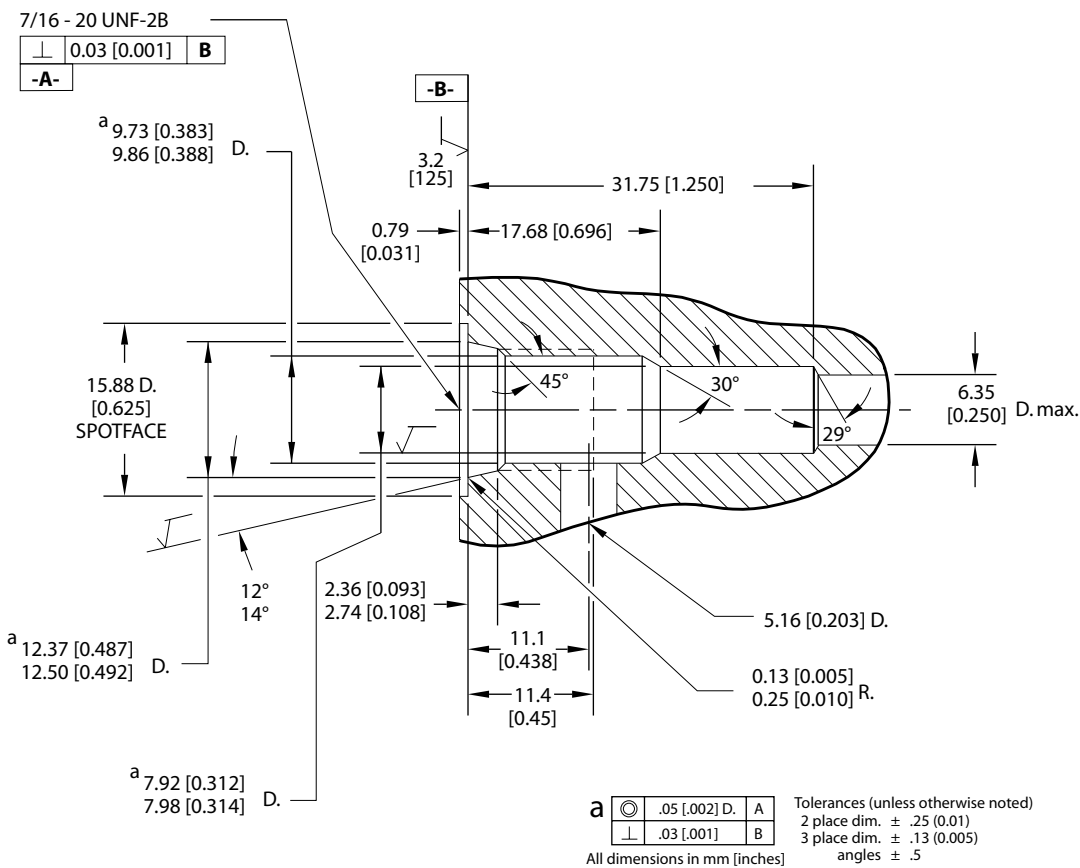

$\sqrt{\quad} = 1.6 [63] \sqrt{\quad}$

P102 815

Form tools

Roughing tool	CP-4-2-RT
Finishing tool	CP-4-2-FT
Tap	7/16-20 UNF-2A

Housings

Order Code	Description	Ports	Page
CP04-2-2B	Aluminum Housing	1/4 BSP	20.6
CP04-2-4S	Aluminum Housing	SAE #4	20.6

Cavities
CP04-2



Cartridge Valves Technical Information
Cavities
CP04-3

Dimensions

mm [in]

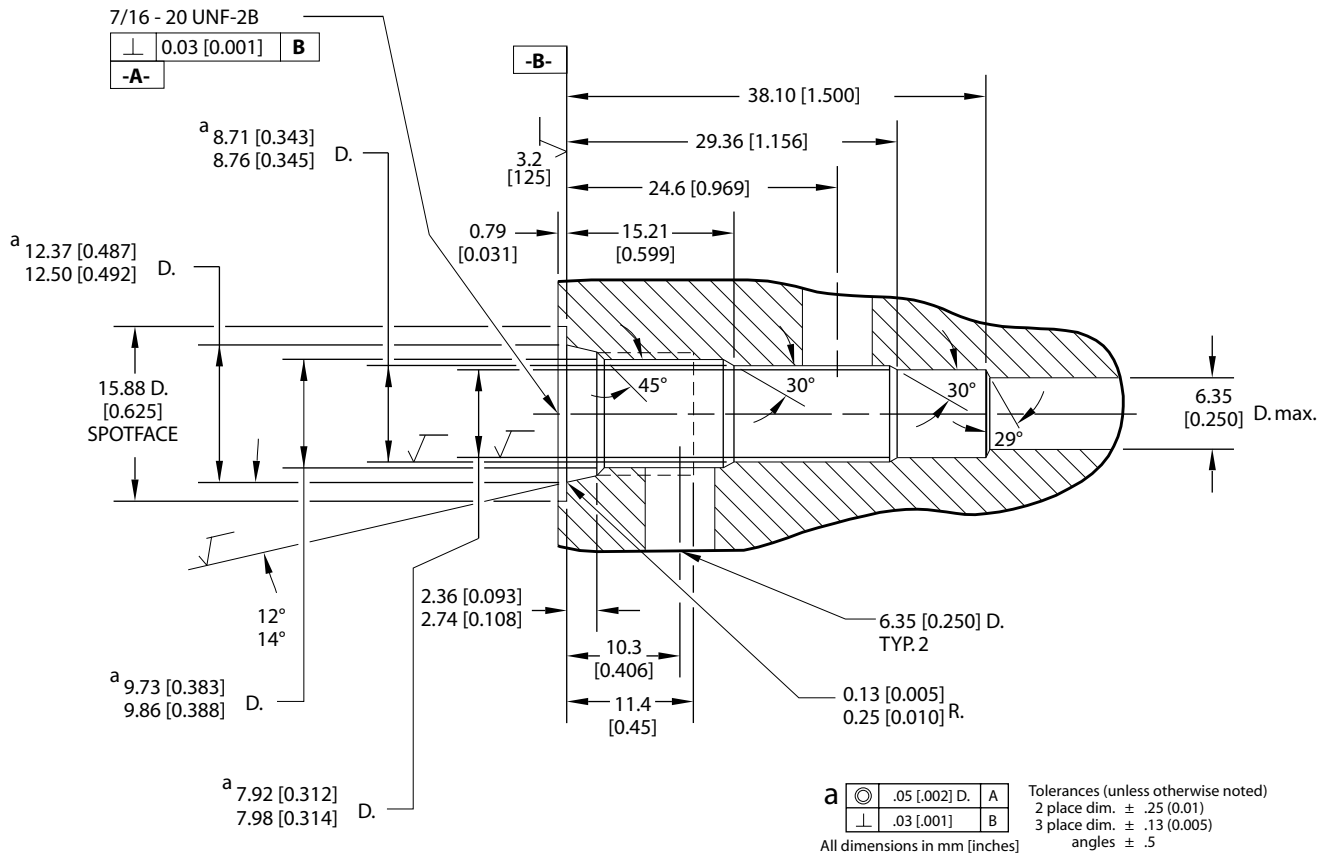

$\sqrt{\quad} = 1.6 [63] \sqrt{\quad}$
P102.769

Form tools

Roughing tool	CP-4-3-RT
Finishing tool	CP-4-3-FT
Tap	7/16-20 UNF-2A

Housings

Order Code	Description	Ports	Page
CP04-3-2B	Aluminum Housing	1/4 BSP	20.7
CP04-3-4S	Aluminum Housing	SAE #4	20.7

Cavities
CP04-3



Cartridge Valves Technical Information

Cavities

CP07-3

Dimensions

mm [in]

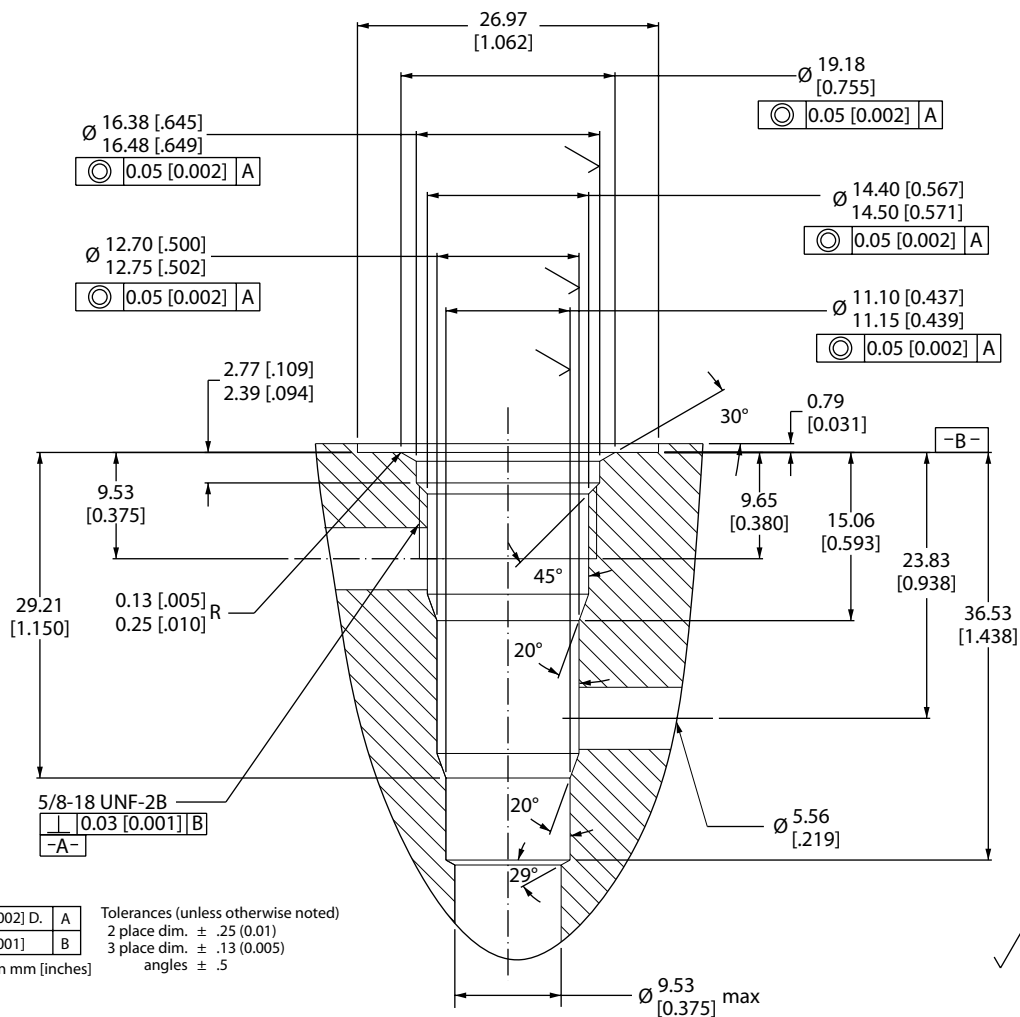

a ◎ .05 [.002] D. A Tolerances (unless otherwise noted)
 ⊥ .03 [.001] B 2 place dim. \pm .25 (0.01)
 3 place dim. \pm .13 (0.005)
 angles \pm .5

$\sqrt{\quad} = 3.13 [125]$

P102 818

Form tools

Roughing tool	CP-7-3-RT
Finishing tool	CP-7-3-FT
Tap	5/8-18 UNF-2A

Housings

Order Code	Description	Ports	Page
CP07-3-4S	Aluminum Housing	SAE #4	20.8

Cavities CP07-3



Cartridge Valves Technical Information
Cavities
CP08-3L

Dimensions

mm [in]

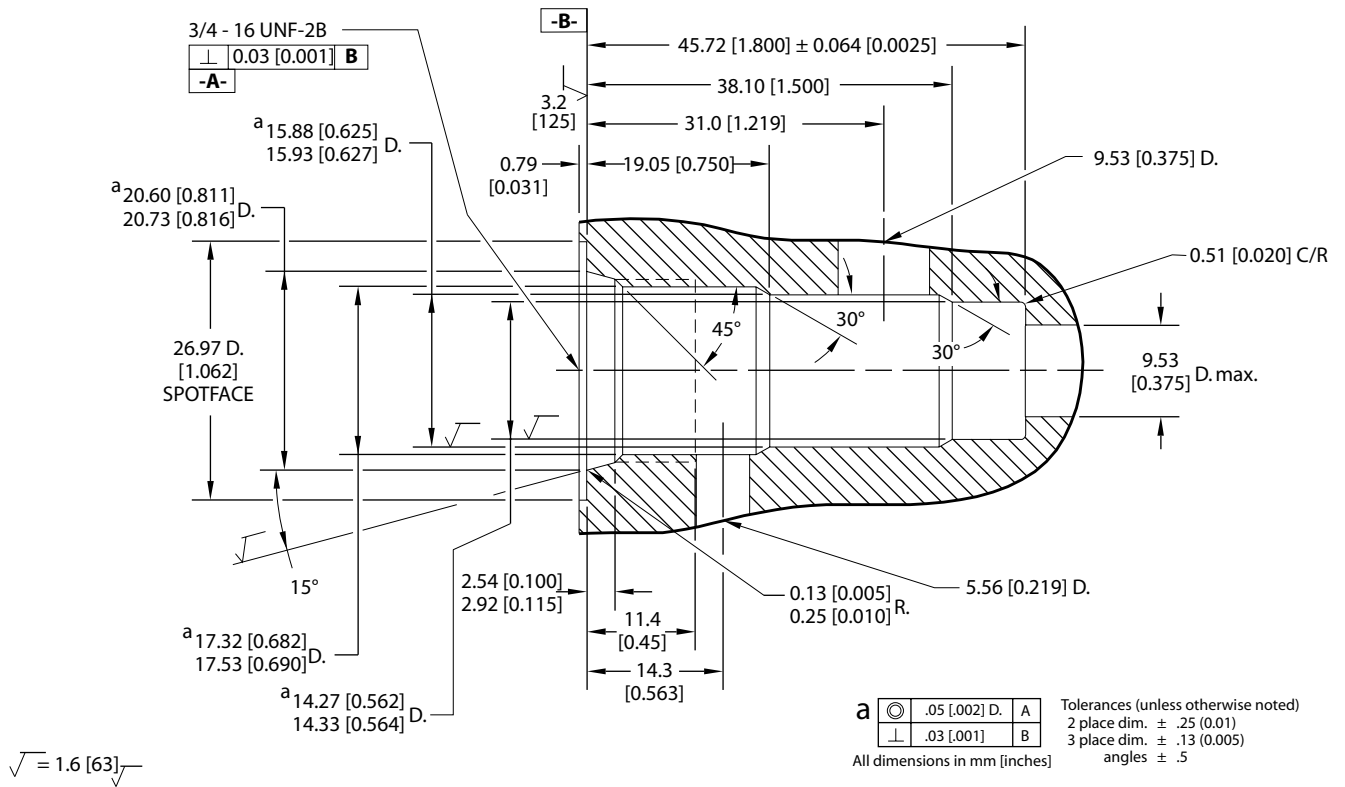

P102 775

Form tools

Roughing tool	CP-8-3L-RT
Finishing tool	CP-8-3L-FT
Tap	3/4-16 UNF-2A

Housings

Order Code	Description	Ports	Page
CP08-3L-2B	Aluminum Housing	1/4 BSP	20.9
CP08-3L-3B	Aluminum Housing	3/8 BSP	20.9
CP08-3L-4S	Aluminum Housing	SAE #4	20.9
CP08-3L-6S	Aluminum Housing	SAE #6	20.9

Cavities
CP08-3L



Cartridge Valves Technical Information

Cavities

CP12-2

Dimensions

mm [in]

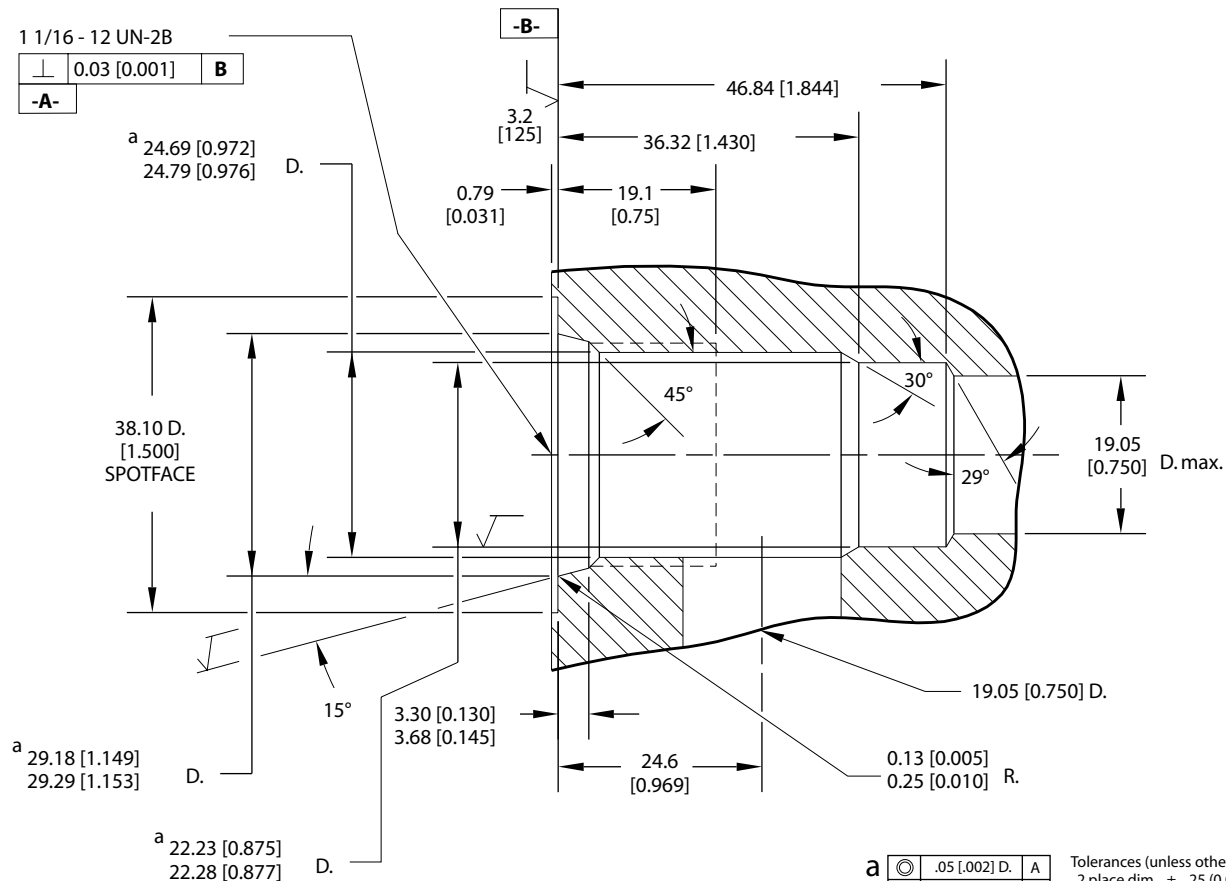

Caution
SDC12-2 and CP12-2 cavities are not interchangeable. Differences in sealing area depth may lead to leakage if the wrong valve is used with this cavity. Use only the specified cavity for each valve.

a

⊙	.05 [0.002] D.	A
⊥	.03 [0.001]	B

 Tolerances (unless otherwise noted)
 2 place dim. ± .25 (0.01)
 3 place dim. ± .13 (0.005)
 angles ± .5

All dimensions in mm [inches]

$$\sqrt{\quad} = 1.6 [63] \sqrt{\quad}$$

P102 789

Form tools

Roughing tool	CP-12-2-RT
Finishing tool	CP-12-2-FT
Tap	1-1/16-12 UN-2A

Housings

Order Code	Description	Ports	Page
CP12-2-10S	Aluminum Housing	SAE #10	20.10
CP12-2-12S	Aluminum Housing	SAE #12	20.10
CP12-2-S10S	Steel Housing	SAE #10	20.10
CP12-2-S12S	Steel Housing	SAE #12	20.10
CP12-2-4B	Aluminum housing	1/2 BSP	20.10
CP12-2-6B	Aluminum housing	3/4 BSP	20.10



Cartridge Valves Technical Information
Cavities
CP12-3

Dimensions

mm [in]

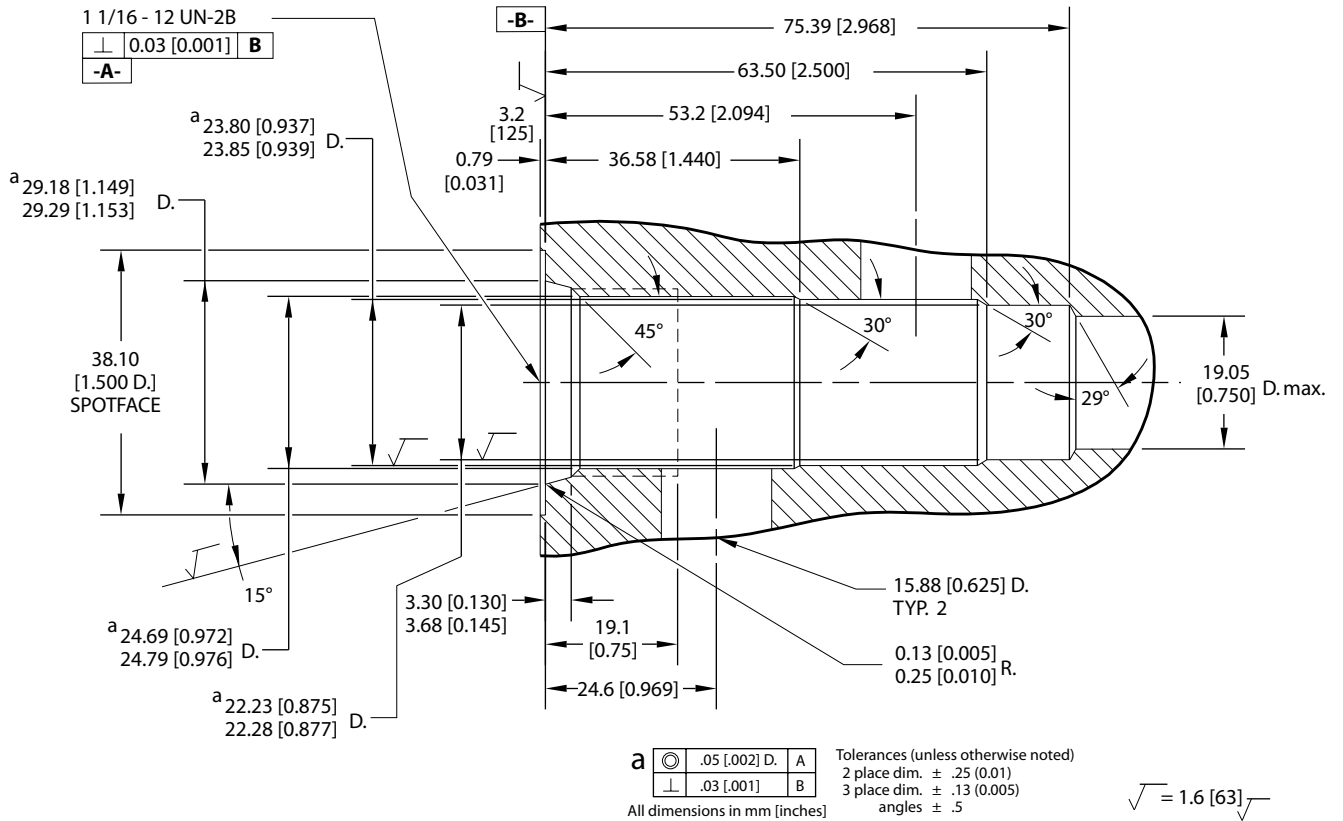

Form tools

Roughing tool	CP-12-3-RT
Finishing tool	CP-12-3-FT
Tap	1-1/16-12 UN-2A

Housings

Order Code	Description	Ports	Page
CP12-3-10S	Aluminum Housing	SAE #10	20.11
CP12-3-12S	Aluminum Housing	SAE #12	20.11
CP12-3-4B	Aluminum Housing	1/2 BSP	20.11
CP12-3-6B	Aluminum Housing	3/4 BSP	20.11
CP12-3-S10S	Steel Housing	SAE #10	20.11
CP12-3-S12S	Steel Housing	SAE #12	20.11

Cavities
CP12-3



Cartridge Valves Technical Information
Cavities
CP12-3M

Dimensions

mm [in]

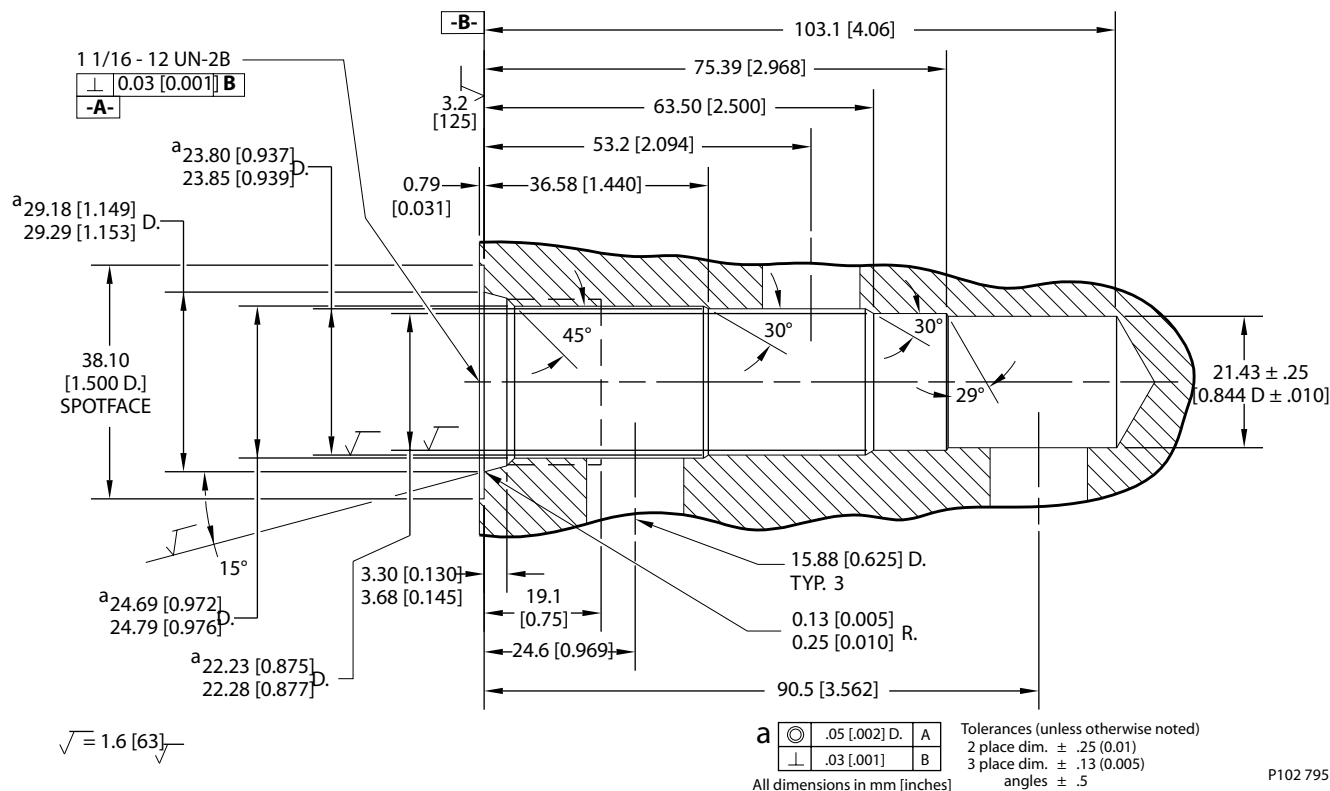

Form tools

Roughing tool	CP-12-3M-RT
Finishing tool	CP-12-3-FT
Tap	1-1/16-12 UN-2A

Housings

Order Code	Description	Ports	Page
CP12-3M-10S	Aluminum Housing	SAE #10	20.12
CP12-3M-12S	Aluminum Housing	SAE #12	20.12
CP12-3M-6B	Aluminum Housing	3/4 BSP	20.12



Cartridge Valves Technical Information

Cavities
CP12-3S

Dimensions

mm [in]

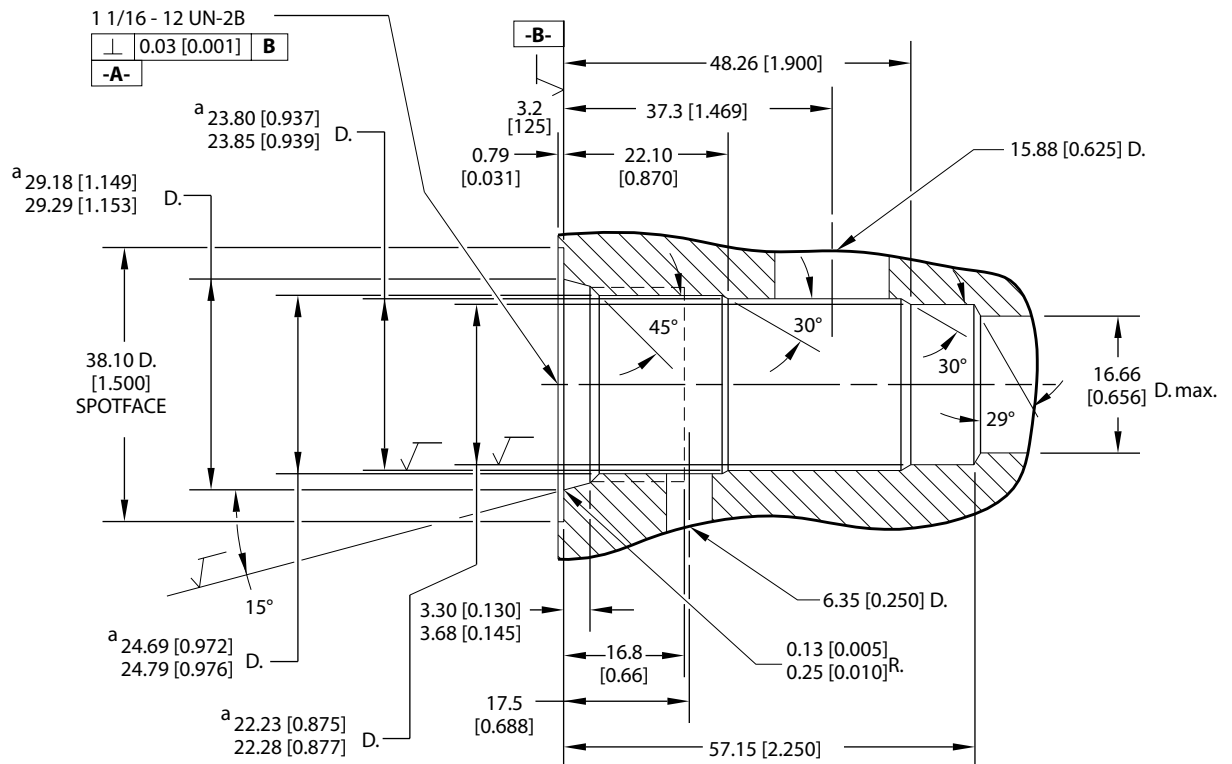

$$\sqrt{\quad} = 1.6 [63] \sqrt{\quad}$$

a	⊙	.05 [0.002] D.	A	Tolerances (unless otherwise noted) 2 place dim. ± .25 (0.01) 3 place dim. ± .13 (0.005) angles ± .5
	⊥	.03 [0.001]	B	
All dimensions in mm [inches]				

P102 791

Form tools

Roughing tool	CP-12-3S-RT
Finishing tool	CP-12-3S-FT
Tap	1-1/16-12 UN-2A

Housings

Order Code	Description	Ports	Page
CP12-3S-10S/4S	Aluminum Housing, Pilot at Port #3	SAE #10, #4	20.13
CP12-3S-12S/4S	Aluminum Housing, Pilot at Port #3	SAE #12, #4	20.13
CP12-3S-4B/2B	Aluminum Housing, Pilot at Port #3	1/2 BSP, 1/4 BSP	20.13
CP12-3S-6B/2B	Aluminum Housing, Pilot at Port #3	3/4 BSP, 1/4 BSP	20.13



Cartridge Valves Technical Information
Cavities
CP12-4

Dimensions

mm [in]

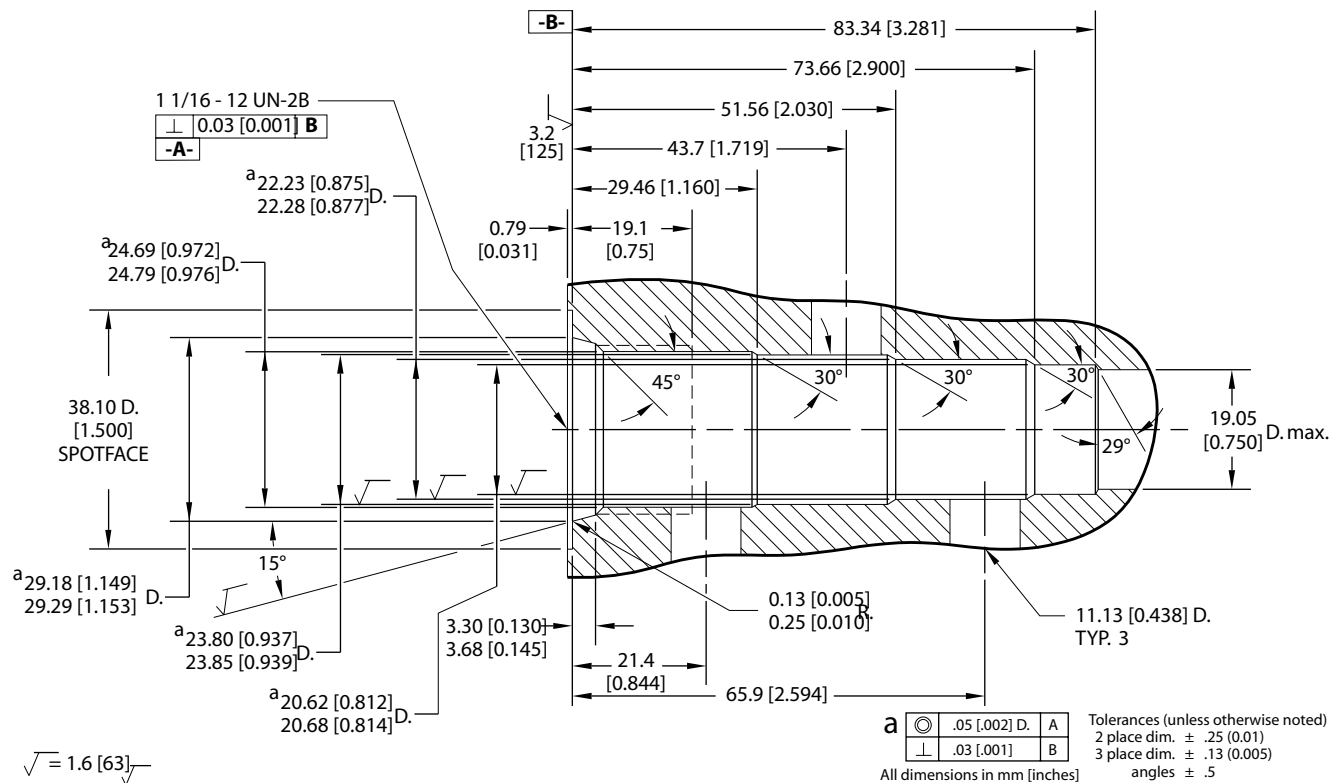

P102 797

Form tools

Roughing tool	CP-12-4-RT
Finishing tool	CP-12-4-FT
Tap	1-1/16-12 UN-2A

Housings

Order Code	Description	Ports	Page
CP12-4-10S	Aluminum Housing	SAE #10	20.14
CP12-4-10S/4S	Aluminum Housing, Pilot at Port #1	SAE #10, #4	20.14
CP12-4-10S-X1	Aluminum Housing, No Port #1	SAE #10	20.14
CP12-4-3B	Aluminum Housing	3/8 BSP	20.14
CP12-4-3B-X1	Aluminum Housing, No Port #1	3/8 BSP	20.14
CP12-4-4B	Aluminum Housing	1/2 BSP	20.14
CP12-4-4B-X1	Aluminum Housing, No Port #1	1/2 BSP	20.14
CP12-4-8S	Aluminum Housing	SAE #8	20.14
CP12-4-8S/4S	Aluminum Housing, Pilot at Port #1	SAE #10, #4	20.14
CP12-4-8S-X1	Aluminum Housing, No Port #1	SAE #8	20.14



Cartridge Valves Technical Information
Cavities
CP16-4

Dimensions

mm [in]

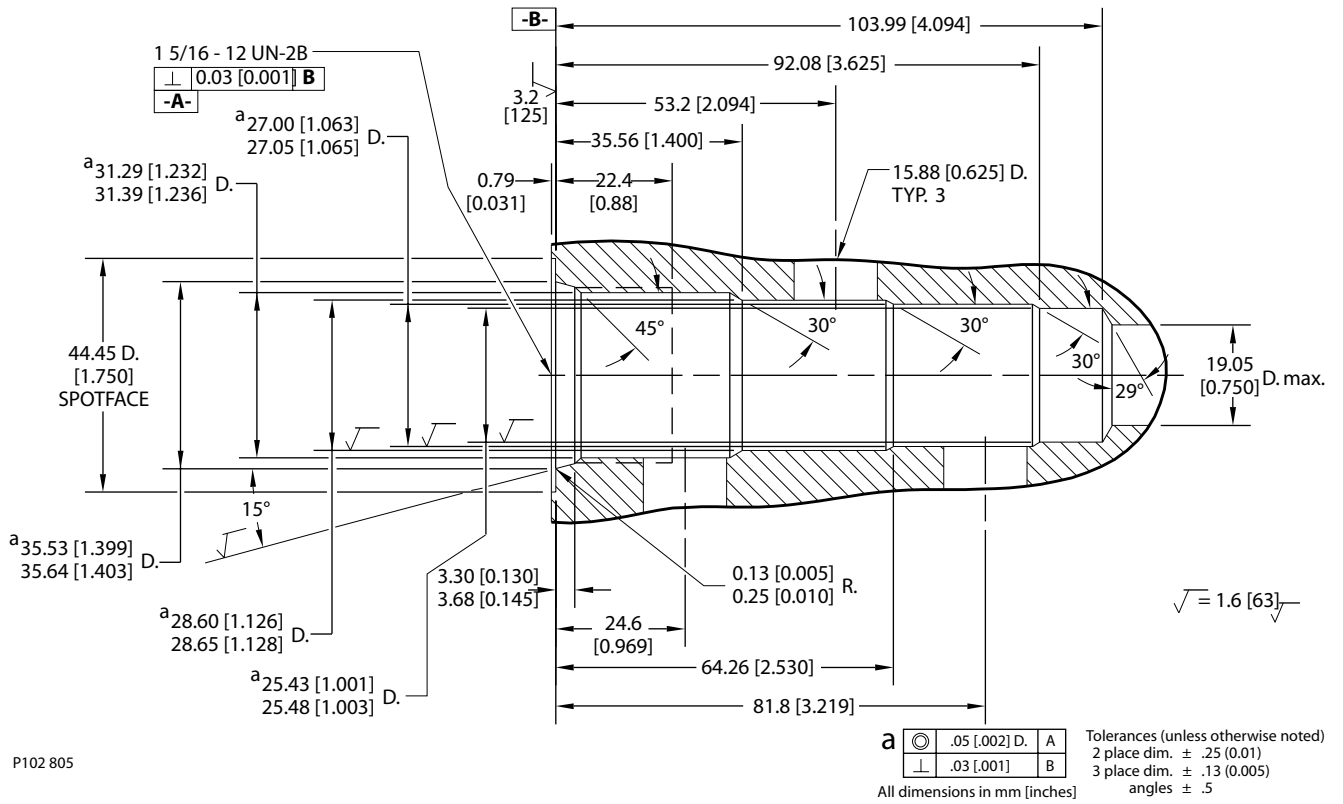

P102 805

Form tools

Roughing tool	CP-16-4-RT
Finishing tool	CP-16-4-FT
Tap	1-5/16-12 UN-2A

Housings

Order Code	Description	Ports	Page
CP16-4-12S	Aluminum Housing	SAE #12	20.16
CP16-4-12S-X1	Aluminum Housing, No Port #1	SAE #12	20.15
CP16-4-16S	Aluminum Housing	SAE #16	20.16
CP16-4-16S-X1	Aluminum Housing, No Port #1	SAE #16	20.15
CP16-4-6B	Aluminum Housing	3/4 BSP	20.16
CP16-4-8B	Aluminum Housing	1 BSP	20.16

Cavities
CP16-4



Cartridge Valves Technical Information

Cavities CP20-3S

Dimensions

mm [in]

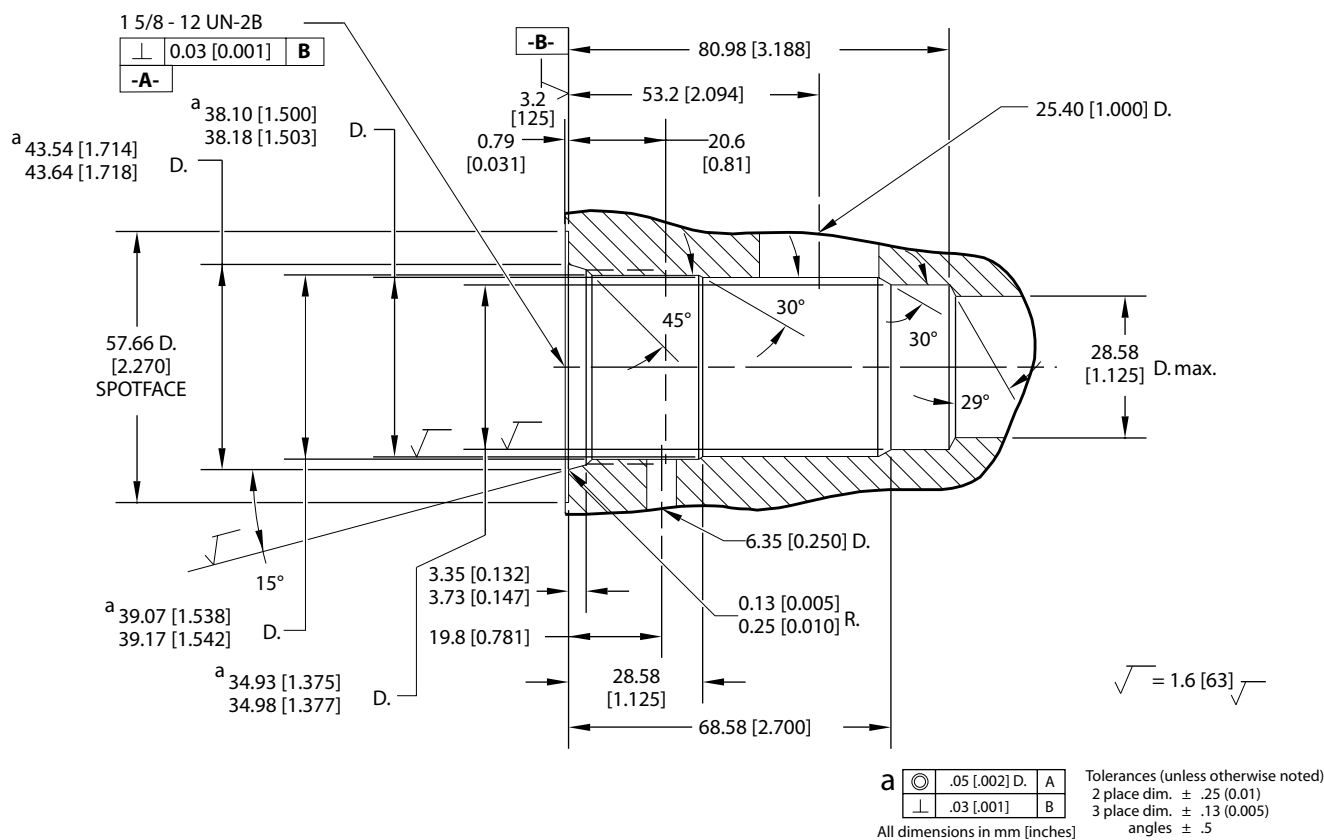

P102 809

Form tools

Roughing tool	CP-20-3S-RT
Finishing tool	CP-20-3S-FT
Tap	1-5/8-12 UN-2A

Housings

Order Code	Description	Ports	Page
CP20-3S-10B/2B	Aluminum Housing, Pilot at Port #3	1 1/4 BSP, 1/4 BSP	20.17
CP20-3S-16S/4S	Aluminum Housing, Pilot at Port #3	SAE #16, #4	20.17
CP20-3S-20S/4S	Aluminum Housing, Pilot at Port #3	SAE #20, #4	20.17
CP20-3S-8B/2B	Aluminum Housing, Pilot at Port #3	1 BSP, 1/4 BSP	20.17



Cartridge Valves Technical Information

Cavities

NCS04/3

Dimensions

mm [in]

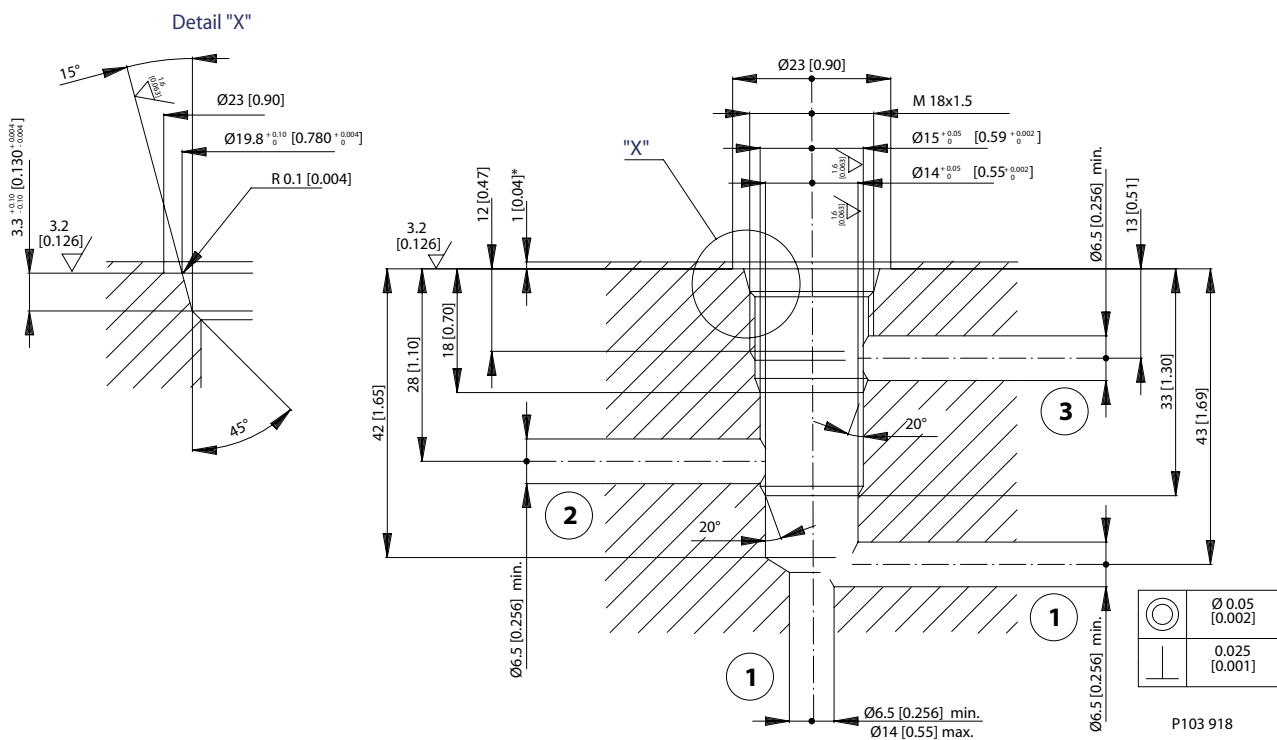

Form tools

High speed steel tool	9507914
Diamond cutting tool	9507923

Housings

Order Code	Description	Ports	Page
NCS04/3-DI-1/4	Alum. Hsg., 2 Cavities w/#3 Ports Conn.	1/4 BSP	20.26
NCS04/3-DI-3/8	Alum. Hsg., 2 Cavities w/#3 Ports Conn.	3/8 BSP	20.26
NCS04/3-DL-1/4	Alum. Hsg., 2 Cavities w/#1 Ports Conn.	1/4 BSP	20.27
NCS04/3-DL-4S	Alum. Hsg., 2 Cavities w/#1 Ports Conn.	SAE #4	20.27
NCS04/3-DL-6S	Alum. Hsg., 2 Cavities w/#1 Ports Conn.	SAE #6	20.27
NCS04/3-SE-1/4	Aluminum Housing	1/4 BSP	20.24
NCS04/3-SE-4S	Aluminum Housing	SAE #4	20.28
NCS04/3-SE-6S	Aluminum Housing	SAE #6	20.28
NCS04/3-SI-1/4	Aluminum Housing, Two #1 Ports	1/4 BSP	20.25
NCS04/3-SI-4S	Aluminum Housing, Two #1 Ports	SAE #4	20.29
NCS04/3-SI-6S	Aluminum Housing, Two #1 Ports	SAE #6	20.29



Cartridge Valves Technical Information
Cavities
NCS06/2

Dimensions

mm [in]

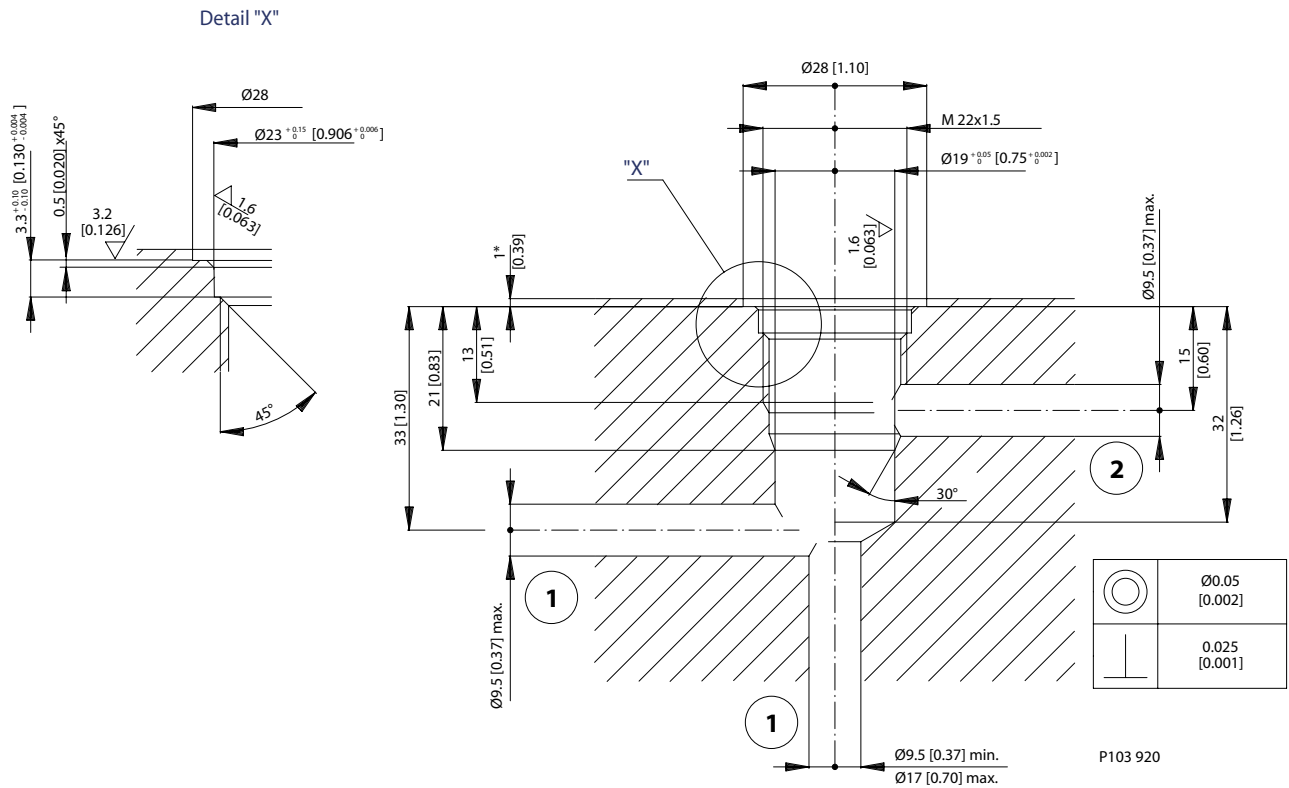

Form tools

High speed steel tool	9506514
Diamond cutting tool	9506523

Housings

Order Code	Description	Ports	Page
NCS06/2-DG-1/2	Aluminum Housing	1/2 BSP	20.34
NCS06/2-DG-3/8	Aluminum Housing	3/8 BSP	20.33
NCS06/2-DG-6S	Aluminum Housing	SAE #6	20.33
NCS06/2-DG-8S	Aluminum Housing	SAE #8	20.34
NCS06/2-LG1-1/2	Aluminum Housing, Two #2 Ports	1/2 BSP	20.36
NCS06/2-LG1-3/8	Aluminum Housing, Two #2 Ports	3/8 BSP	20.37
NCS06/2-LG1-8S	Aluminum Housing, Two #2 Ports	SAE #8	20.36
NCS06/2-LG2-1/2	Aluminum Housing, Two #1 Ports	1/2 BSP	20.32
NCS06/2-LG2-3/8	Aluminum Housing, Two #1 Ports	3/8 BSP	20.35
NCS06/2-LG2-6S	Aluminum Housing, Two #1 Ports	SAE #6	20.35
NCS06/2-LG2-8S	Aluminum Housing, Two #1 Ports	SAE #8	20.32



Cartridge Valves Technical Information
Cavities
NCS06/3

Dimensions

mm [in]

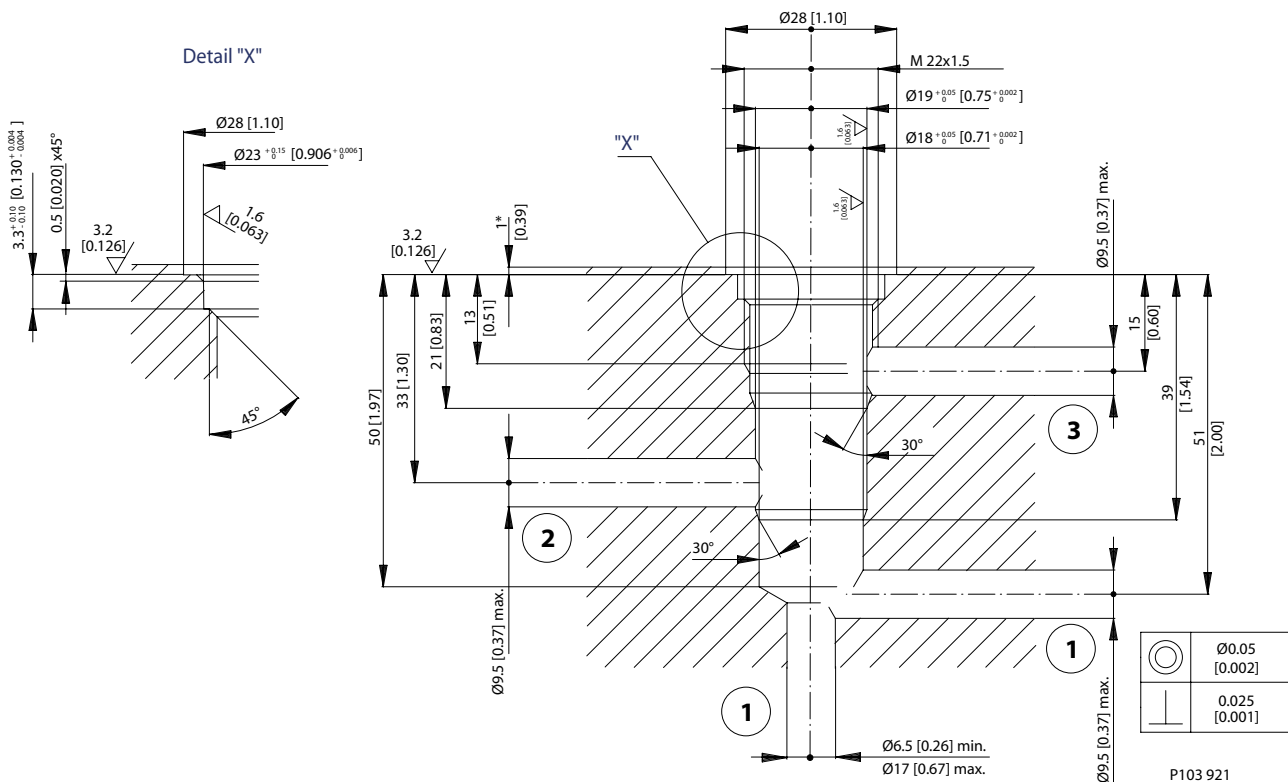

Form tools

High speed steel tool	9505614
Diamond cutting tool	9505623

Housings

Order Code	Description	Ports	Page
NCS06/3-DL-1/2	Alum. Hsg., 2 Cavities w/#1 Ports Conn.	1/2 BSP	20.38
NCS06/3-DL-3/8	Alum. Hsg., 2 Cavities w/#1 Ports Conn.	3/8 BSP	20.45
NCS06/3-DL-6S	Alum. Hsg., 2 Cavities w/#1 Ports Conn.	SAE #6	20.45
NCS06/3-DL-8S	Alum. Hsg., 2 Cavities w/#1 Ports Conn.	SAE #8	20.38
NCS06/3-LD-6S	Aluminum Housing, No Port #1	SAE #6	20.39
NCS06/3-LD-8S	Aluminum Housing, No Port #1	SAE #8	20.40
NCS06/3-SE-1/2	Aluminum Housing	1/2 BSP	20.41
NCS06/3-SE-3/8	Aluminum Housing	3/8 BSP	20.42
NCS06/3-SE-6S	Aluminum Housing	SAE #6	20.42
NCS06/3-SE-8S	Aluminum Housing	SAE #8	20.41
NCS06/3-SI-1/2	Aluminum Housing, Two #1 Ports	1/2 BSP	20.44
NCS06/3-SI-3/8	Aluminum Housing, Two #1 Ports	3/8 BSP	20.43
NCS06/3-SI-6S	Aluminum Housing, Two #1 Ports	SAE #6	20.43
NCS06/3-SI-8S	Aluminum Housing, Two #1 Ports	SAE #8	20.44



Cartridge Valves Technical Information
Cavities
NCS06/4

Dimensions

mm [in]

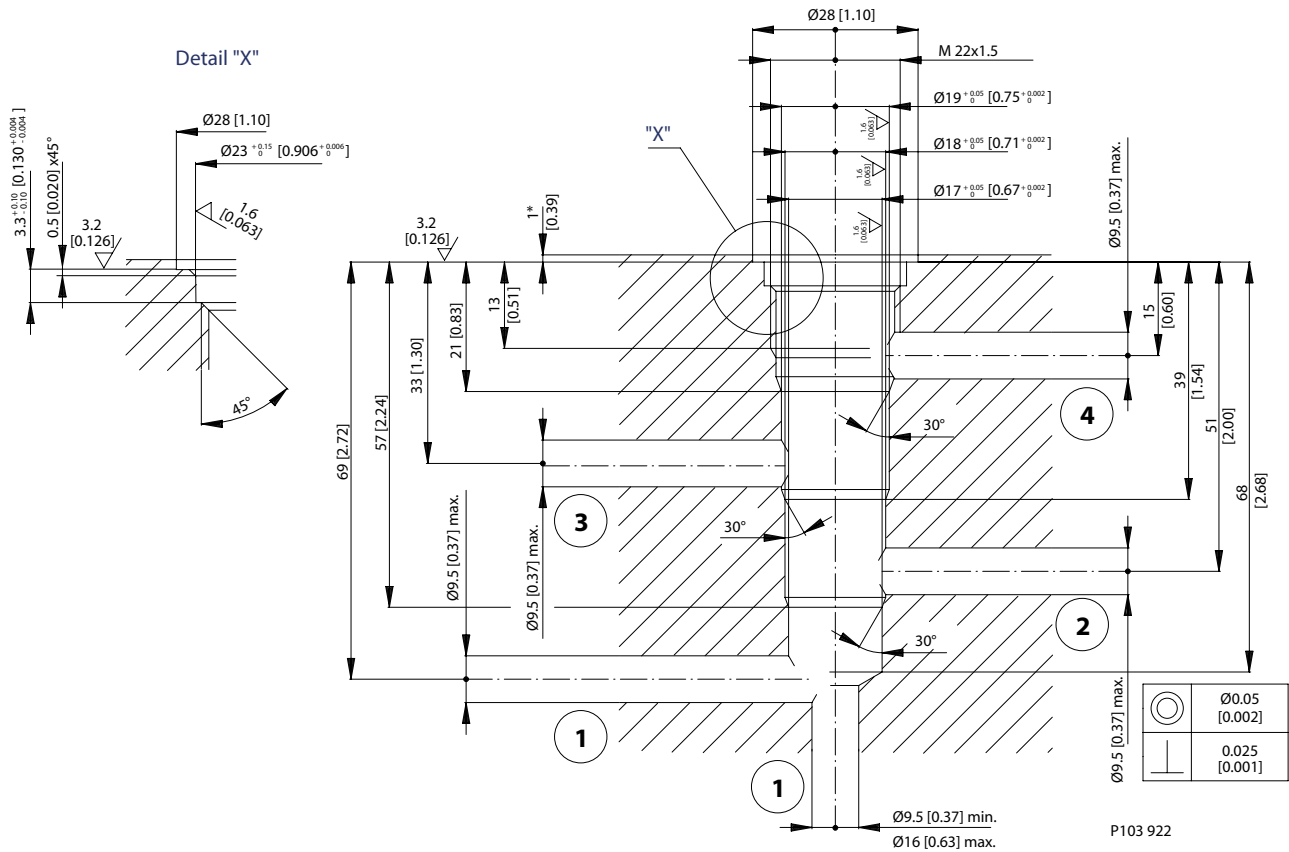

Form tools

High speed steel tool	9506413
Diamond cutting tool	9506423

Housings

Order Code	Description	Ports	Page
NCS06/4-L-1/2	Aluminum Housing	1/2 BSP	20.47
NCS06/4-L-3/8	Aluminum Housing	3/8 BSP	20.49
NCS06/4-L-6S	Aluminum Housing	SAE #6	20.49
NCS06/4-L-8S	Aluminum Housing	SAE #8	20.47
NCS06/4-LD-1/2	Aluminum Housing, No Port #1	1/2 BSP	20.48
NCS06/4-LD-3/8	Aluminum Housing, No Port #1	3/8 BSP	20.46

Cavities
NCS06/4

Dimensions

mm [in]

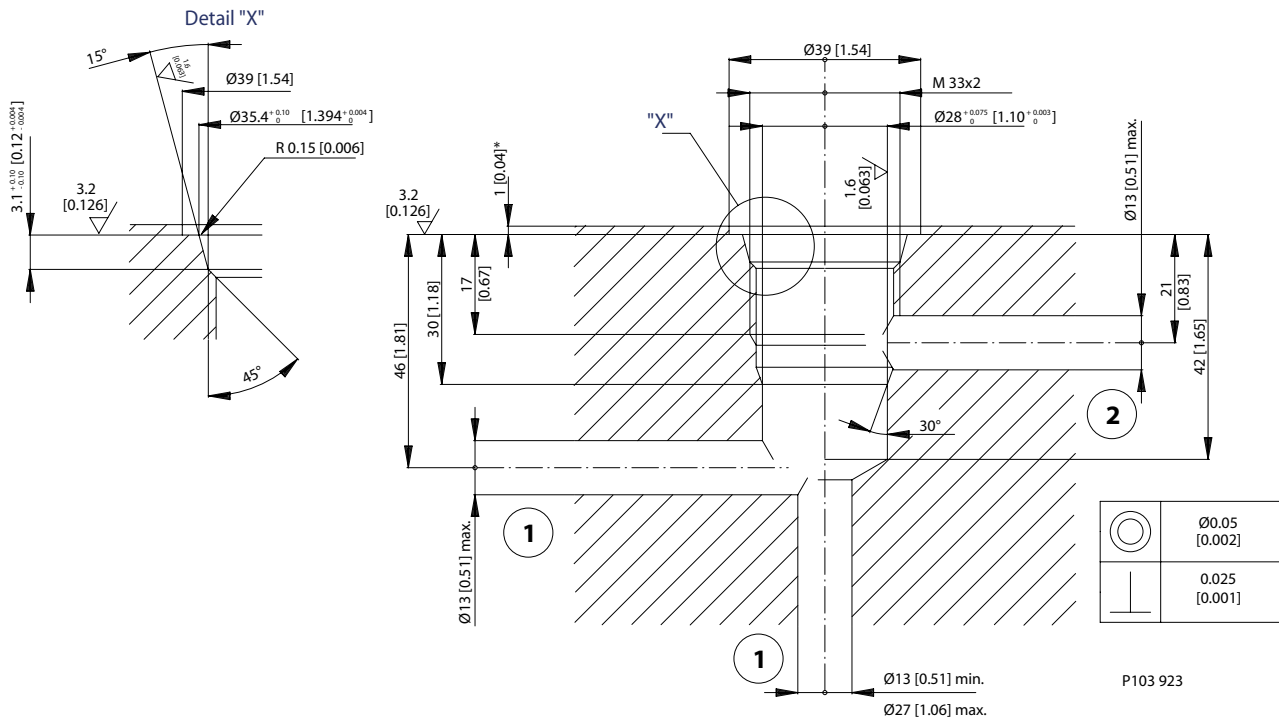

Form tools

High speed steel tool	9506913
Diamond cutting tool	9506923

Housings

Order Code	Description	Ports	Page
NCS12/2-DG-1/2	Aluminum Housing	1/2 BSP	20.50
NCS12/2-DG-12S	Aluminum Housing	SAE #12	20.50
NCS12/2-DG-3/4	Aluminum Housing	3/4 BSP	20.50
NCS12/2-DG-8S	Aluminum Housing	SAE #8	20.50
NCS12/2-LG1-12S	Aluminum Housing, Two #2 Ports	SAE #12	20.51
NCS12/2-LG1-8S	Aluminum Housing, Two #2 Ports	SAE #8	20.51
NCS12/2-LG2-1/2	Aluminum Housing, Two #1 Ports	1/2 BSP	20.52
NCS12/2-LG2-12S	Aluminum Housing, Two #1 Ports	SAE #12	20.52
NCS12/2-LG2-3/4	Aluminum Housing, Two #1 Ports	3/4 BSP	20.52
NCS12/2-LG2-8S	Aluminum Housing, Two #1 Ports	SAE #8	20.52



Cartridge Valves Technical Information

Cavities

NCS12/3

Dimensions

mm [in]

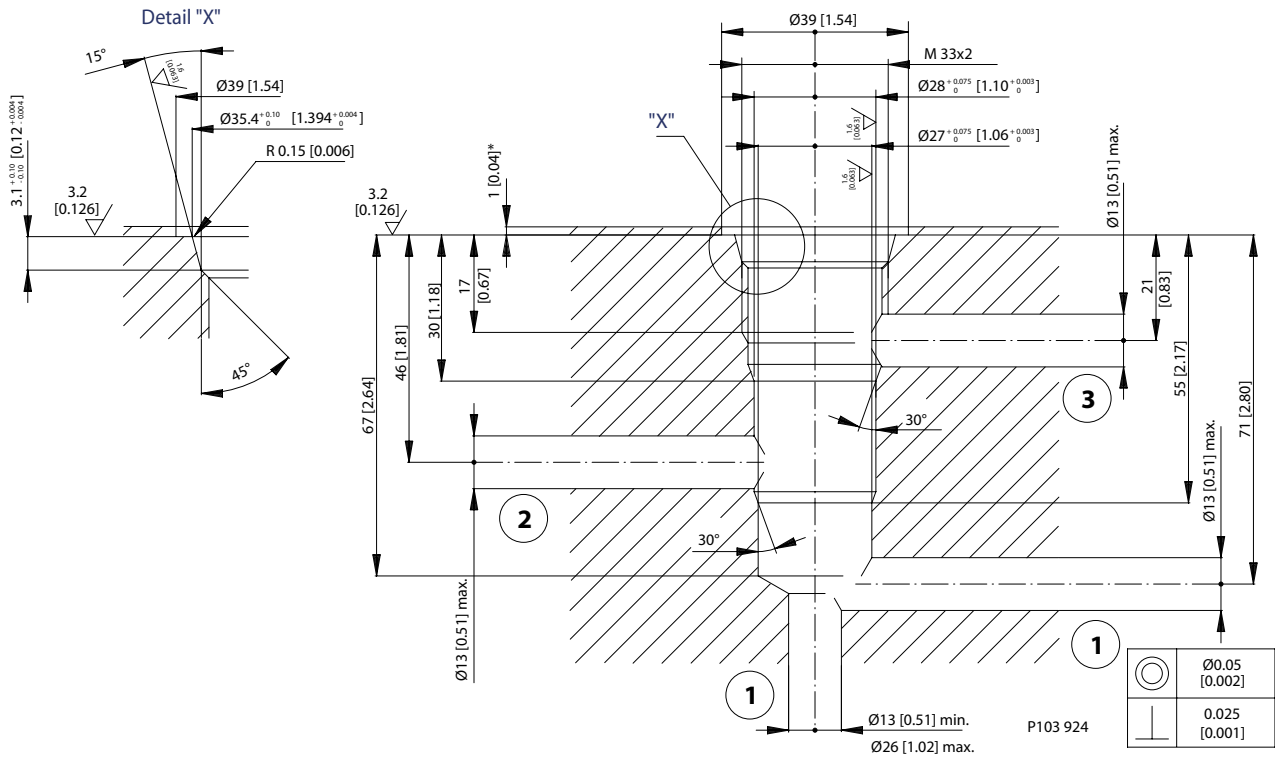

Form tools

High speed steel tool	9507013
Diamond cutting tool	9507022

Housings

Order Code	Description	Ports	Page
NCS12/3-DL-1/2	Alum. Hsg., 2 Cavities w/#1 Ports Conn.	1/2 BSP	20.54
NCS12/3-DL-12S	Alum. Hsg., 2 Cavities w/#1 Ports Conn.	SAE #12	20.53
NCS12/3-DL-3/4	Alum. Hsg., 2 Cavities w/#1 Ports Conn.	3/4 BSP	20.55
NCS12/3-DL-8S	Alum. Hsg., 2 Cavities w/#1 Ports Conn.	SAE #8	20.53
NCS12/3-SE-1	Aluminum Housing	1/2 BSP	20.56
NCS12/3-SE-12S	Aluminum Housing	SAE #12	20.56
NCS12/3-SE-3/4	Aluminum Housing	3/4 BSP	20.56
NCS12/3-SE-8S	Aluminum Housing	SAE #8	20.56
NCS12/3-SI-1	Aluminum Housing, Two #1 Ports	1/2 BSP	20.57
NCS12/3-SI-12S	Aluminum Housing, Two #1 Ports	SAE #12	20.57
NCS12/3-SI-3/4	Aluminum Housing, Two #1 Ports	3/4 BSP	20.57
NCS12/3-SI-8S	Aluminum Housing, Two #1 Ports	SAE #8	20.57

Cavities
NCS12/3



Cartridge Valves Technical Information

Cavities

NCS12/4

Dimensions

mm [in]

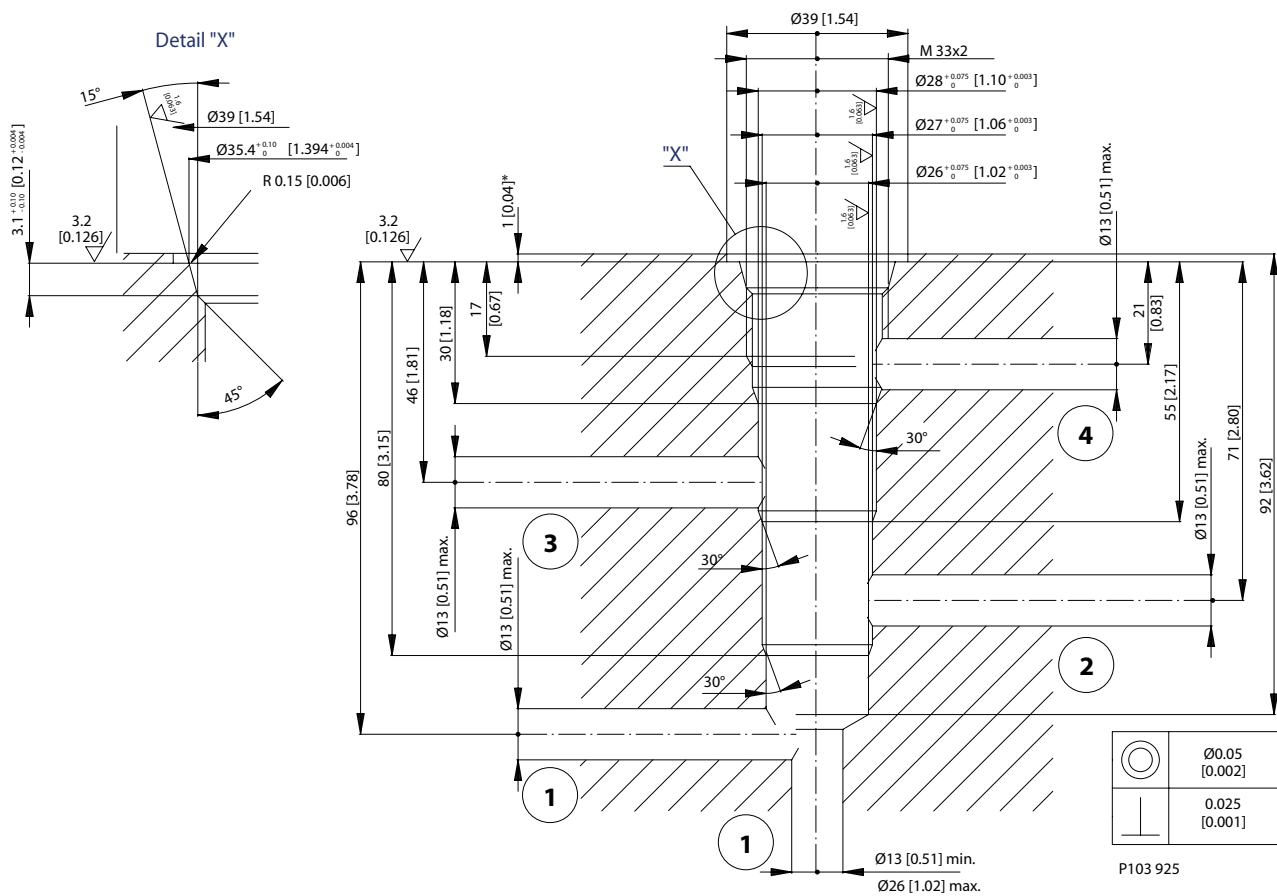

Form tools

High speed steel tool	9507113
Diamond cutting tool	9507122

Housings

Order Code	Description	Ports	Page
NCS12/4-HD-1	Aluminum Housing, No Port #1	1/2 BSP	20.59
NCS12/4-L-1	Aluminum Housing	1/2 BSP	20.58
NCS12/4-L-12S	Aluminum Housing	SAE #12	20.60
NCS12/4-L-3/4	Aluminum Housing	3/4 BSP	20.58



Cartridge Valves Technical Information
Cavities
VME06

Dimensions

mm [in]

TOLERANCES UNLESS OTHERWISE SPECIFIED

Diameter and Lengths:
if < 18mm ± 0.1 [0.004]
Angles ± 2°

3.2 [125]
▽

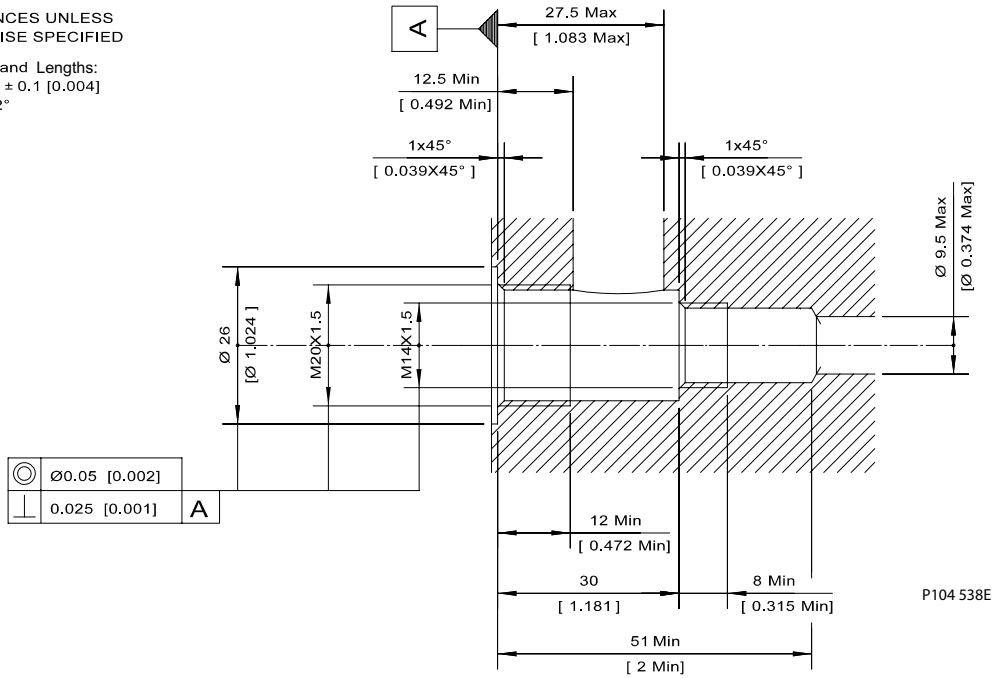

P104 538E

Form tools

High speed steel tool	9503014
-----------------------	---------

Housings

Order Code	Description	Ports	Page
VME 06-DG-3B	Aluminum Housing	3/8 BSP	20.109
VME 06-DG-6S	Aluminum Housing	SAE #6	20.109
VME 06-LG-3B	Aluminum Housing	3/8 BSP	20.108
VME 06-LG-6S	Aluminum Housing	SAE #6	20.108



Cartridge Valves Technical Information

Cavities

VME07

Dimensions

mm [in]

TOLERANCES UNLESS OTHERWISE SPECIFIED

Diameter and Lengths:
if < 18mm ± 0.1 [0.004]
Angles ± 2°

3.2 [125]

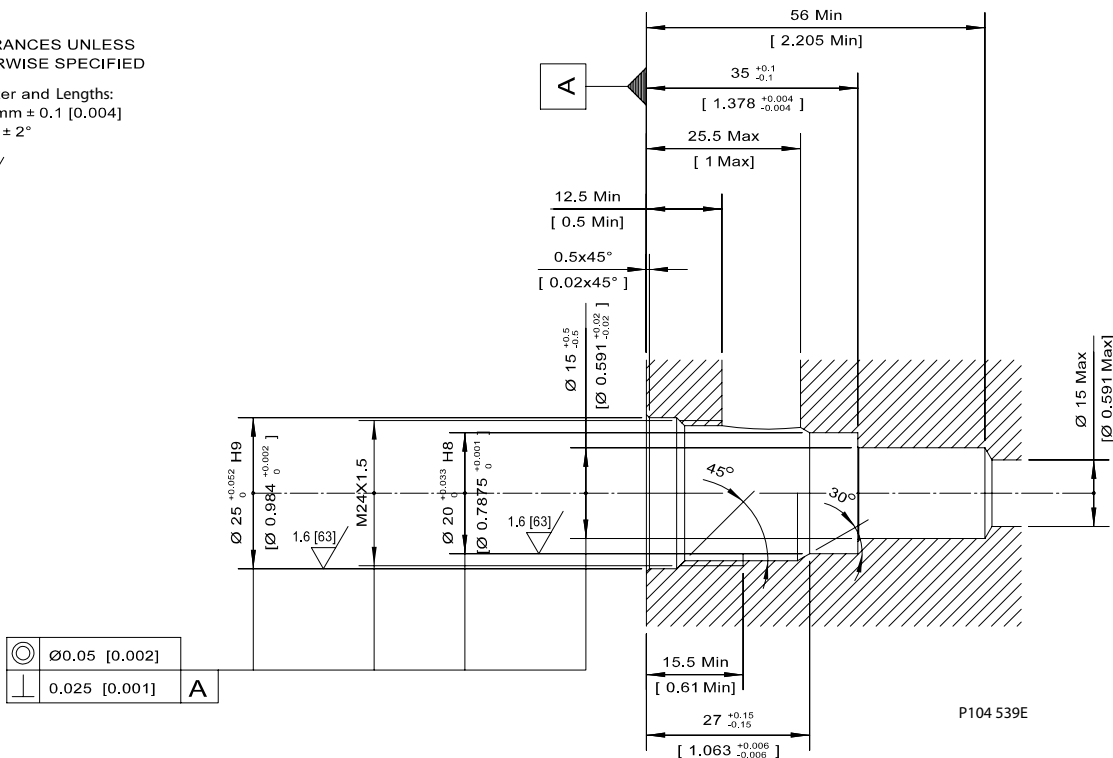

P104 539E

Form tools

High speed steel tool	9501014
-----------------------	---------

Housings

Order Code	Description	Ports	Page
VME 07-DG-4B	Aluminum Housing	1/2 BSP	20.110
VME 07-DG-8S	Aluminum Housing	SAE #8	20.110
VME 07-LG-4B	Aluminum Housing	1/2 BSP	20.111
VME 07-LG-8S	Aluminum Housing	SAE #8	20.111



Cartridge Valves Technical Information
Cavities
VME08

Dimensions

mm [in]

TOLERANCES UNLESS OTHERWISE SPECIFIED

Diameter and Lengths:
if < 18mm ± 0.1 [0.004]
Angles ± 2°

3.2 [125]

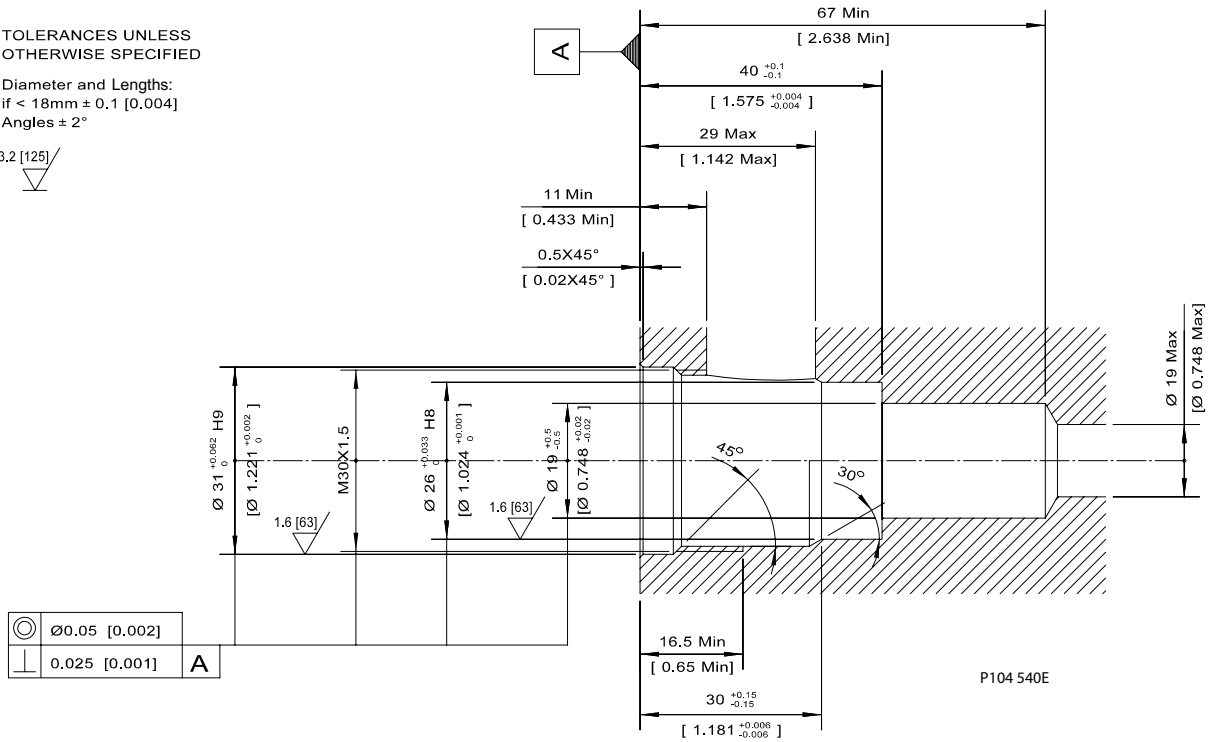

	Ø0.05 [0.002]	A
	0.025 [0.001]	A

Form tools

High speed steel tool	9500914
-----------------------	---------

Housings

Order Code	Description	Ports	Page
VME 08-DG-12S	Aluminum Housing	SAE #12	20.113
VME 08-DG-6B	Aluminum Housing	3/4 BSP	20.113
VME 08-LG-12S	Aluminum Housing	SAE #12	20.112
VME 08-LG-6B	Aluminum Housing	3/4 BSP	20.112



Cartridge Valves Technical Information

Cavities FC-144

Dimensions

mm [in]

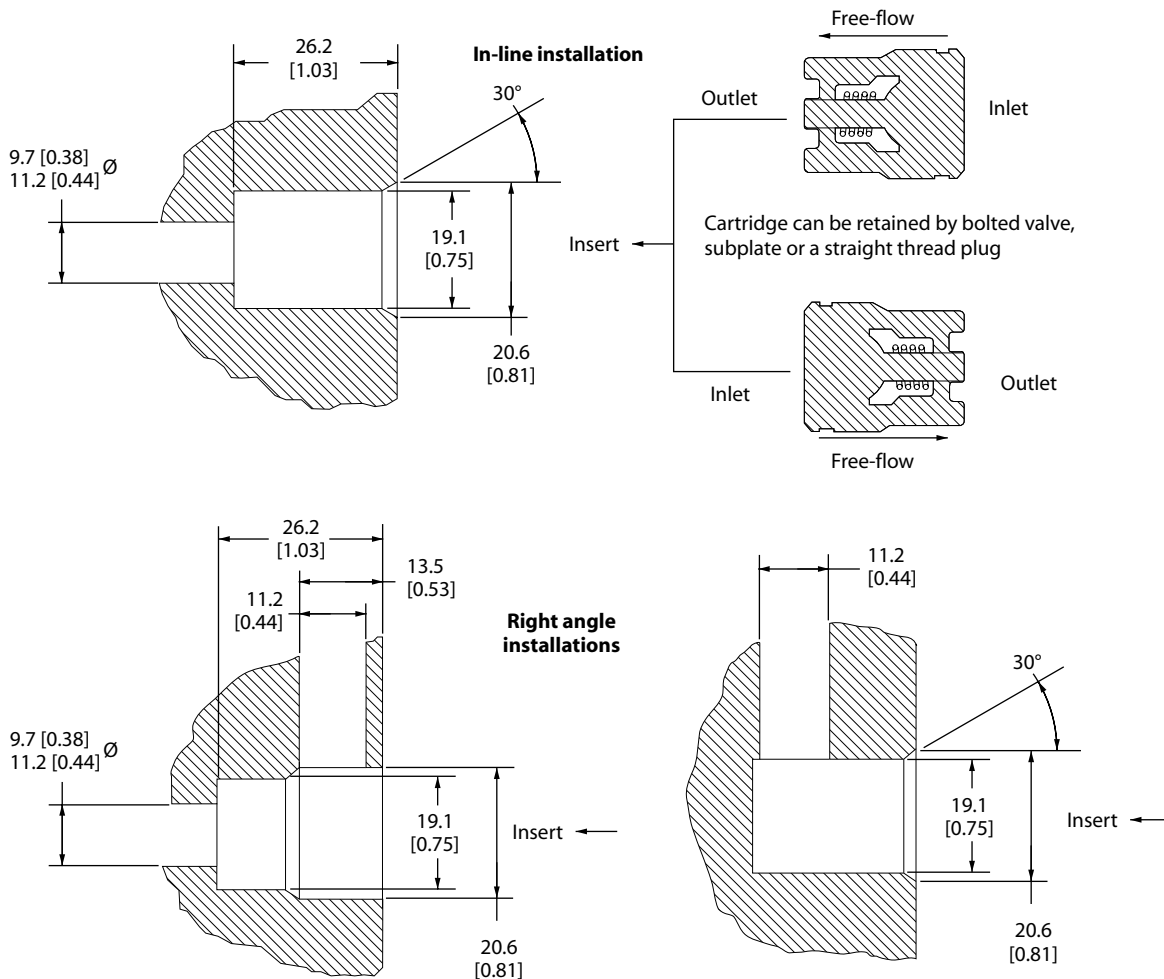

Form tools

Roughing tool	FC-144-RT
Finishing tool	FC-144-FT

Cavities FC-144



Cartridge Valves Technical Information

Cavities FC-304

Dimensions

mm [in]

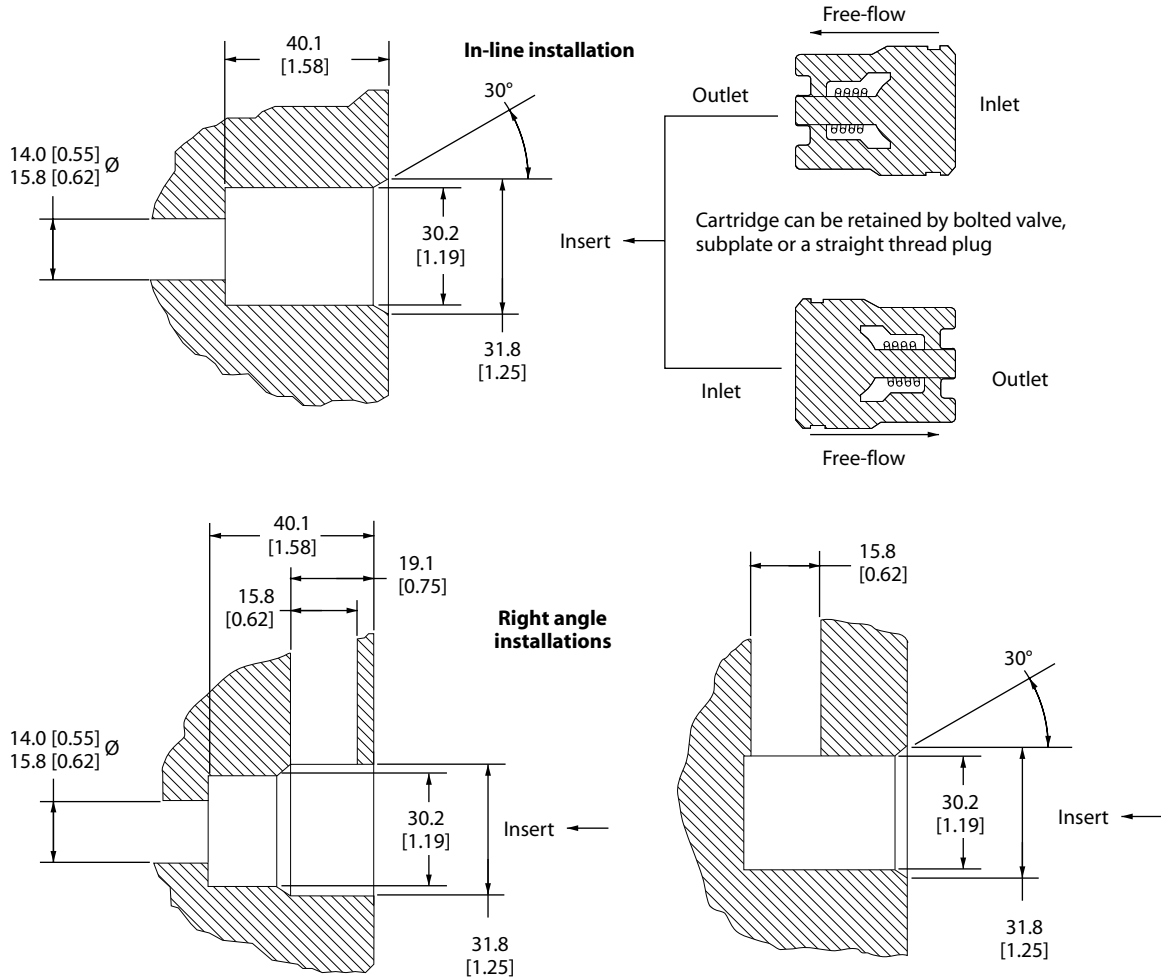

P102 820

Form tools

Roughing tool	FC-304-RT
Finishing tool	FC-304-FT

Cavities
FC-304



Cartridge Valves Technical Information
Cavities
FC-336

Dimensions

mm [in]

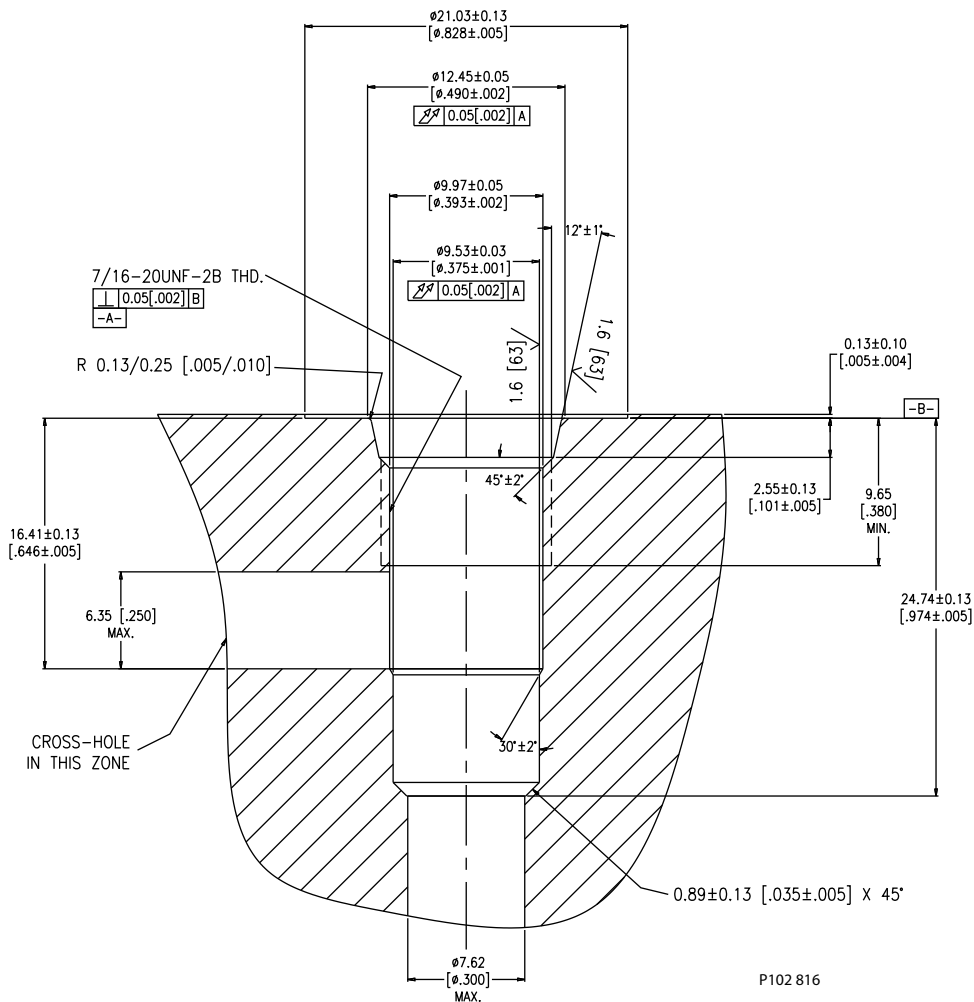

P102 816

Form tools

Roughing tool	FC-336-RT
Finishing tool	FC-336-FT

Housings

Order Code	Description	Ports	Page
FC336-4S	Aluminum Housing	SAE #4	20.18

Cavities
FC-336



Cartridge Valves Technical Information
Cavities
ISO D03

Dimensions

mm [in]

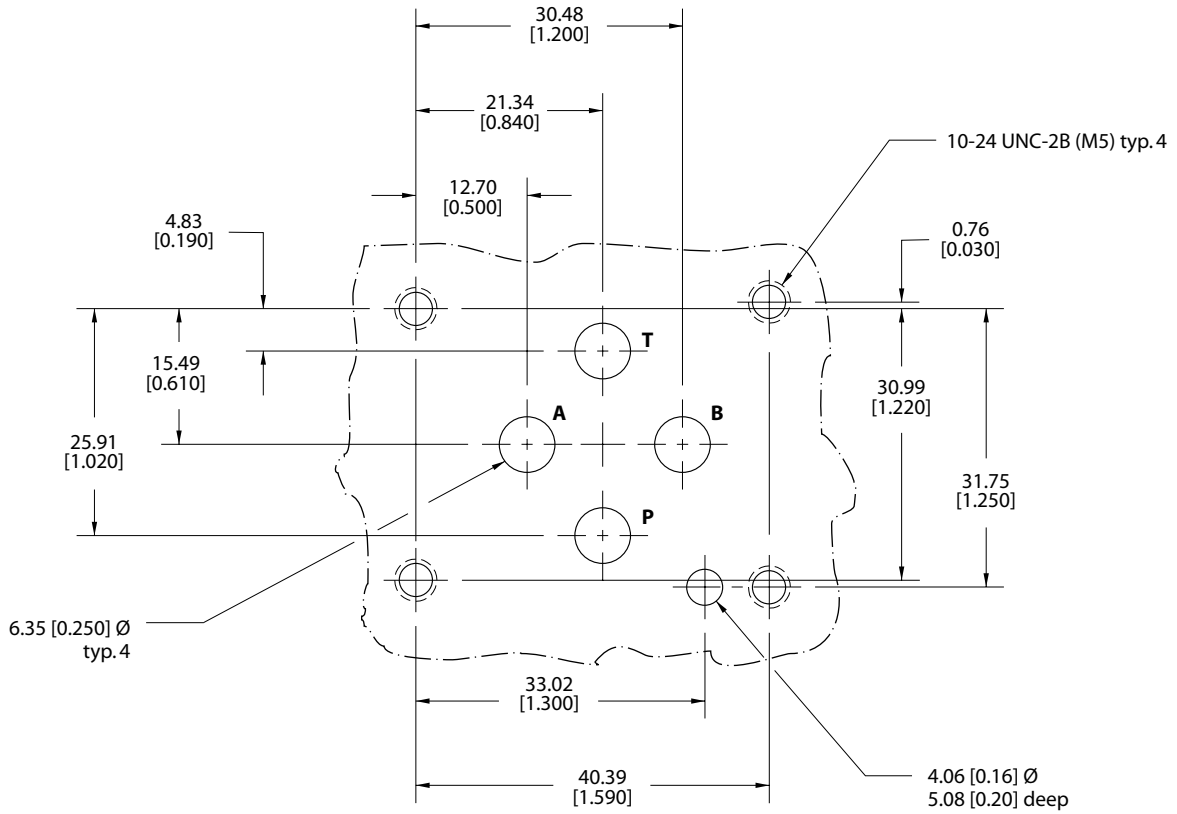

P102 926E

Housings

Order Code	Description	Ports	Page
UDPS-06-AL	ISO D03 Subplate, Aluminum	#8 SAE	20.19
UDPS-06-DI	ISO D03 Subplate, Ductile Iron	#8 SAE	20.19

Cavities
ISO D03



Cartridge Valves Technical Information
Cavities
ISO D05

Dimensions

mm [in]

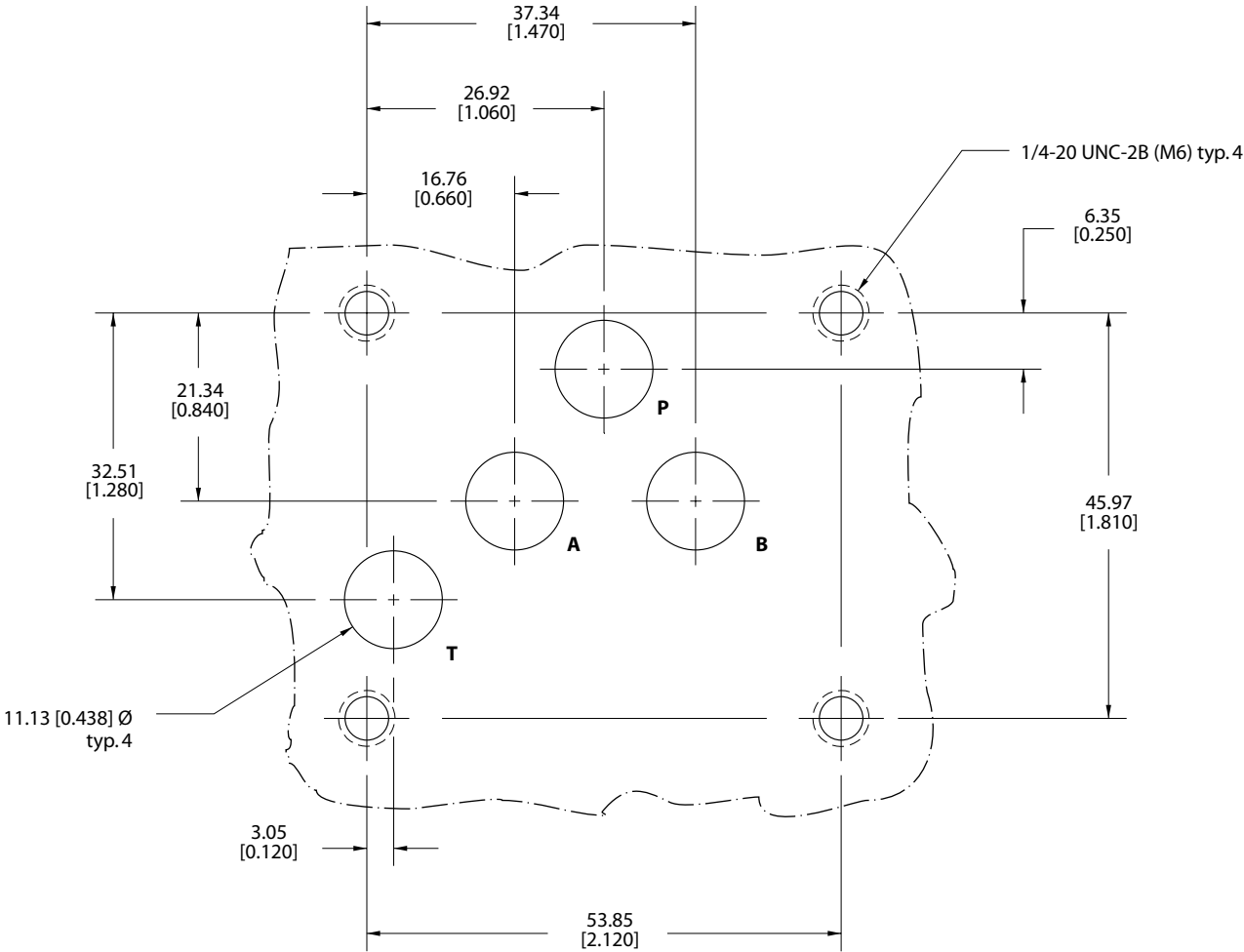

P102 927E

Housings

Order Code	Description	Ports	Page
UDPS-10-AL	ISO D05 Subplate, Aluminum	#8 SAE	20.20
UDPS-10-DI	ISO D05 Subplate, Ductile Iron	#8 SAE	20.20

Cavities
ISO D05