

Model Shown:  
**RC2402P**



**Features**

**LOW HEIGHT POSITIVE MECHANICAL LOCK TO SUPPORT EXTENDED LOAD HOLDING.**

- Compact design where space is limited.
- Locking collar designed to support lifted load for extended periods of time with hydraulic pressure released.
- Integral tilt saddle comes standard and improves performance under side load, reducing the effects of off-center loading
- Overflow port (weep hole) prevents piston from being overextended under load.
- Special coating improves corrosion and abrasion resistance.
- Equipped with 3/8" NPTF female half couplers.

**Technical Dimensions**

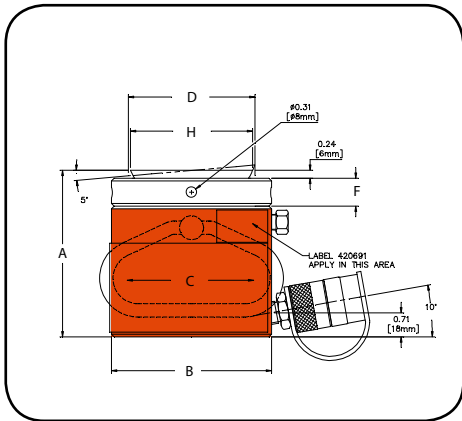

Pancake locking cylinders are ideal for tight quartered locations.



**Ordering Information**

Cyl. Cap.	Stroke	Order No.	Oil Cap.	A	B	C	D	E	F	G	H	Metric Tons at 700	Prod. Wt.
				Retracted Height	Outside Dia.	Bore Dia.	Piston Thread Dia.	Base to Port	Nut Thickness	Swivel Cap Protrusion	Swivel Cap Dia.		
(ton)	(mm)		(cm <sup>3</sup> )	(mm)	(mm)	(mm)	(mm)	(mm)	(mm)	(mm)	(mm)	(bar)	(kg)
55	50,8	RC0552P	355	125	120	95	3.74 x 4	19	21	6	92	50	11
100	44,5	RC1002P	597	137	165	130	5.12 x 6	21	31	8	126	100	22
155	44,5	RC1552P	905	148	205	160	6.30 x 6	27	38	9	148	155	39
240	44,5	RC2402P	1413	155	255	200	7.87 x 6	28	40	10	157	240	59
380	44,5	RC3802P	2208	178	320	250	9.84 x 6	35	50	11	240	380	110
620	44,5	RC6202P	3617	192	405	320	12.60 x 6	38	60	10	295	620	193