

RV50-26 Relief, Pilot-Operated Spool

U.S. Patent
No. 7,137,406

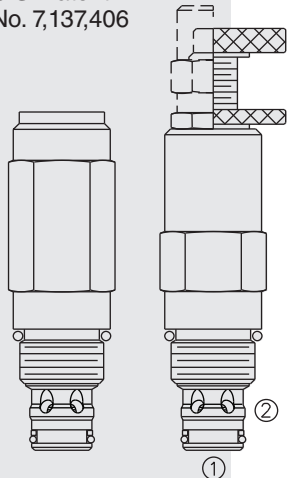

ISO SYMBOL

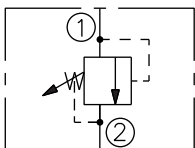

PERFORMANCE (Cartridge Only)

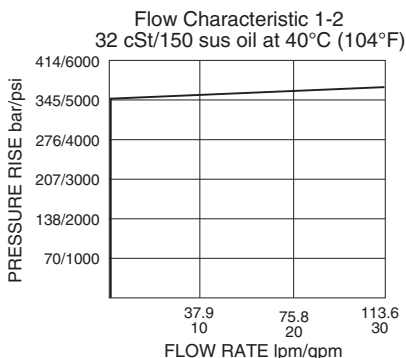

DESCRIPTION

A screw-in, cartridge-style, pilot-operated (two-stage), spool-type hydraulic relief valve, intended for use as a pressure limiting device in demanding hydraulic circuits which require fast response and low hysteresis.

OPERATION

The RV50-26 blocks flow from 1 to 2 until sufficient pressure is present at 1 to force the piloting relief off its seat, allowing the main (second stage) spool to shift, opening 1 to 2.

The cartridge offers smooth transition in response to load changes in demanding hydraulic circuits.

NOTE: The RV50-26 may not be used in cross-over relief applications (back pressure on 2).

FEATURES

- Adjustments cannot be backed out of the valve.
- Adjustments prohibit springs from going solid.
- Hardened spool and cage for long life.
- Fast, smooth response to pressure surges.
- Industry common cavity.

RATINGS

Operating Pressure: 345 bar (5000 psi)

Proof Pressure: 517.1 bar (7500 psi)

Burst Pressure: 1037.7 bar (15050 psi)

Flow Rating: 113.6 lpm (30 gpm) at maximum pressure.

Internal Leakage at Port 2 at 85% of max crack: 147 cc/minute (9 cu. in./minute)

Relief Pressure Setting Defined: bar (psi) evident at 7.57 lpm (2.0 gpm)

Reseat Pressure: Nominal 90% of crack pressure

Relief Pressure Range: 20.7 to 344.7 bar (300 to 5000 psi) Spring range shown in the To Order section. Due to manufacturing tolerances, it may be possible to adjust the valve either lower or higher than the nominal rating shown. **If the valve is adjusted beyond the recommended maximum pressure range for the F and H style adjuster options, the valve may not open to relieve system pressure.**

Cycle Life: 500,000 cycles at 241.3 bar (3500 psi)

Temperature: -54 to 107°C (-65 to 225°F) with polyurethane or urethane seals

Filtration: See page 9.010.1

Fluids: Mineral-based or synthetics with lubricating properties at viscosities of 7.4 to 420 cSt (50 to 2000 sus); See Temperature and Oil Viscosity, page 9.060.1

Installation: No restrictions; See page 9.020.1

Cavity: VC10-2; See page 9.110.1

Cavity Tool: CT10-2XX; See page 8.600.1

Seal Kit: SK10-2X-B with polyurethane seals; SK10-2U-0 with urethane seals; See page 8.650.1

RV50-26

DIMENSIONS

U.S. Patent No. 7,137,406

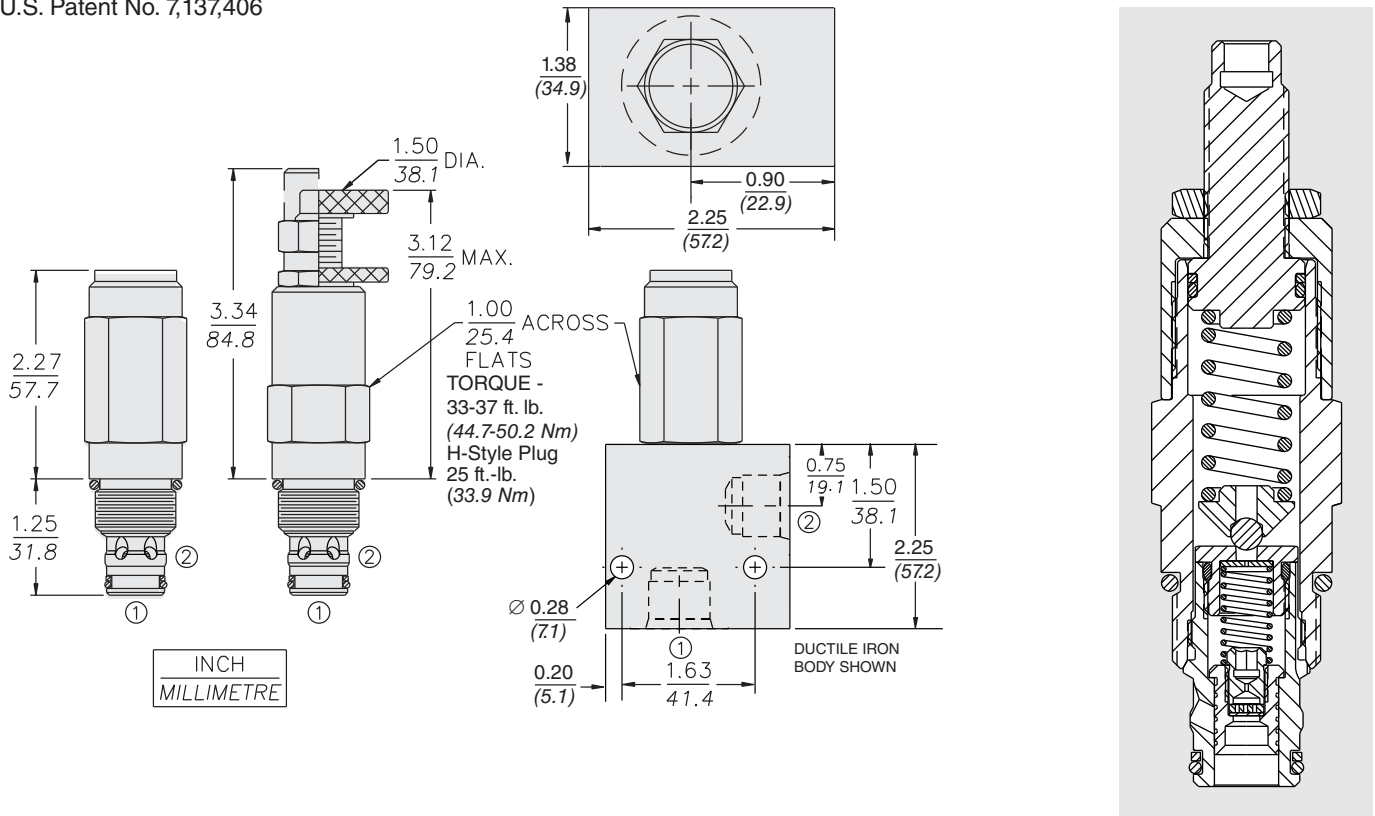

MATERIALS

Cartridge: Weight: 0.24-0.29 kg (0.53-0.65 lb) depending on adjustment option Steel with hardened work surfaces. Zinc-plated exposed surfaces. Polyurethane seals with Fluorocarbon back-ups for pressures over 240 bar (3500 psi). Anodized aluminum knobs.

Ported Body: Weight: 0.54 kg (1.2 lb) Ductile iron (code "D") standard, consult factory for weight, dimensions may differ. Rated to 345 bar (5000 psi). See page 8.010.1

TO ORDER

RV50-26 - - - /

Adjustment Option

- 1/4 in. Hex Allen Head **A**
- 1-1/2 in. Dia. Alum. Knob **B**
- Option A w/ Cover Cap **C**
- Factory Preset Non-Adj. **F***
- Factory Preset Hidden Adjustment **H***
- Option C with Lockwire Holes **L**

* If the valve is adjusted beyond the recommended maximum pressure range for the F and H style adjuster options, the valve may not open to relieve system pressure.

Setting in bar

(Blank)[†] for Adjustable, or Specify, for example:

M240 240 bar

Setting in psi

(Blank)[†] for Adjustable, or Specify, for example:

36.0 3500 psi

[†]Adjustable valves will be preset to approx. 50% of spring max. potential.

Seals

P Polyurethane (Std.)

NOTE: Polyurethane seals required for operation at 345 bar (5000 psi).

Porting

- Cartridge Only **0**
- SAE 6 **6TD**
- SAE 8 **8TD**
- 3/8 in. BSP* **3BD**
- 1/2 in. BSP* **4BD**

*BSP Body; U.K. Mfr. Only

Spring Range

50 27.6 to 345 bar (400 to 5000 psi)

Due to manufacturing tolerances, it may be possible to adjust the valve either lower or higher than the nominal rating shown above.