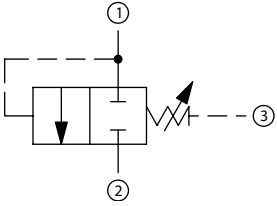
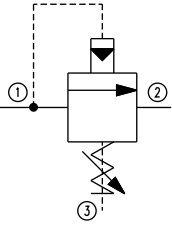
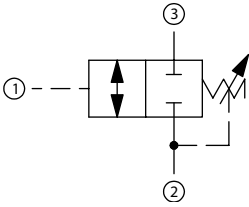
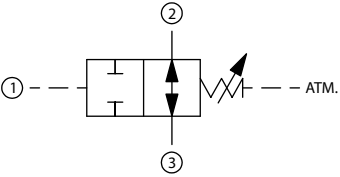
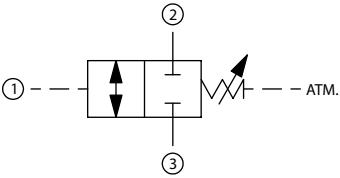

Symbol	Model No.	Cavity	Description	Flow*	Pressure	Page
	CP240-8	SDC10-3	Sequence valve (int. pilot, ext. drain)	55 l/min [14 US gal/min]	210 bar [3000 psi]	06.9
	CP241-8	CP12-3S		150 l/min [39 US gal/min]	40 bar [600 psi]	06.10

Symbol	Model No.	Cavity	Description	Flow*	Pressure	Page
	CP240-21	SDC10-3	Sequence valve (int. pilot, ext. drain, p.o.)	45 l/min [12 US gal/min]	350 bar [5000 psi]	06.11
	CP241-21	CP12-3S		75 l/min [20 US gal/min]	350 bar [5000 psi]	06.12

Symbol	Model No.	Cavity	Description	Flow*	Pressure	Page
	CP240-2	SDC10-3	Sequence valve (ext. pilot, int. drain)	35 l/min [9 US gal/min]	210 bar [3000 psi]	06.13

Symbol	Model No.	Cavity	Description	Flow*	Pressure	Page
	VDP 06/NA	NCS06/3	2w 2p normally closed, pilot operated spool (atmospheric vent)	25 l/min [7 US gal/min]	315 bar [4500 psi]	06.14

Symbol	Model No.	Cavity	Description	Flow*	Pressure	Page
	VDP 06/NC	NCS06/3	2w 2p normally open, pilot operated spool (atmospheric vent)	25 l/min [7 US gal/min]	315 bar [4500 psi]	06.15

* Flow ratings are based on a pressure drop of 7 bar [100 psi] unless otherwise noted. They are for comparison purposes only.

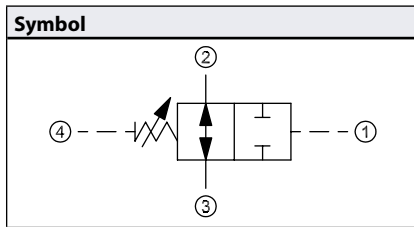
Symbol	Model No.	Cavity	Description	Flow*	Pressure	Page
	CP240-5	SDC10-4	Sequence valve	25 l/min [7 US gal/min]	210 bar [3000 psi]	06.16

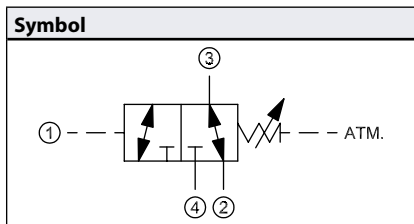
Symbol	Model No.	Cavity	Description	Flow*	Pressure	Page
	VDP 06/42 01	NCS06/4	3w 2p pilot operated spool (atmospheric vent)	22 l/min [6 US gal/min]	315 bar [4500 psi]	06.17

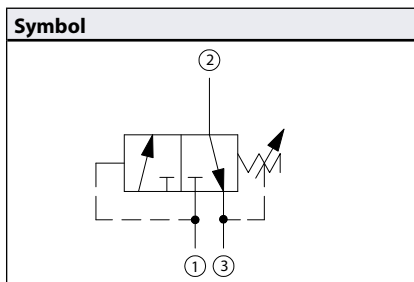
Symbol	Model No.	Cavity	Description	Flow*	Pressure	Page
	CP240-1	SDC10-3	Sequence valve (int. pilot, int. drain)	25 l/min [7 US gal/min]	210 bar [3000 psi]	06.18
	VDP 06/32 01	NCS06/3		30 l/min [8 US gal/min]	315 bar [4500 psi]	06.19

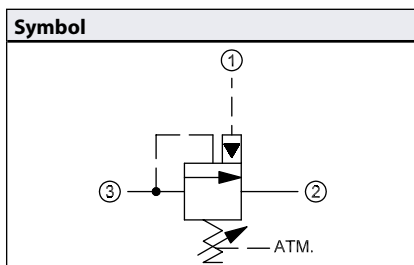
Symbol	Model No.	Cavity	Description	Flow*	Pressure	Page
	VDB 12-CN	NCS12/3	Unloading valve (atmospheric vent)	160 l/min [42 US gal/min]	350 bar [5000 psi]	06.20

* Flow ratings are based on a pressure drop of 7 bar [100 psi] unless otherwise noted. They are for comparison purposes only.

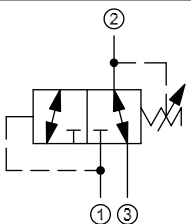
Symbol	Model No.	Cavity	Description	Flow*	Pressure	Page
	CP240-9	SDC10-3	Sequence valve	20 l/min [5 US gal/min]	210 bar [3000 psi]	06.21

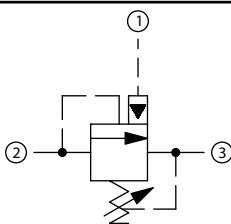
Symbol	Model No.	Cavity	Description	Flow*	Pressure	Page
	CP240-30	SDC10-3	Sequence valve (unloading)	4 l/min [1 US gal/min]	210 bar [3000 psi]	06.22

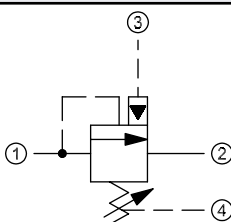
Symbol	Model No.	Cavity	Description	Flow*	Pressure	Page
	AUV06	NCS06/4	Unloading valve	50 l/min [13 US gal/min]	250 bar [3600 psi]	06.23

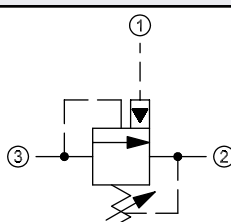
Symbol	Model No.	Cavity	Description	Flow*	Pressure	Page
	VDB 06-EN	NCS06/3	Unloading valve	80 l/min [21 US gal/min]	350 bar [5000 psi]	06.24
	VDB 12-EN	NCS12/3		160 l/min [42 US gal/min]		06.25

* Flow ratings are based on a pressure drop of 7 bar [100 psi] unless otherwise noted. They are for comparison purposes only.

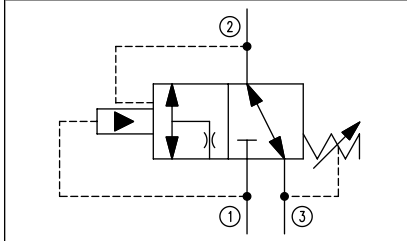
Symbol	Model No.	Cavity	Description	Flow*	Pressure	Page
	CP240-22	SDC10-3	Sequence valve (kick down)	45 l/min [12 US gal/min]	350 bar [5000 psi]	06.26

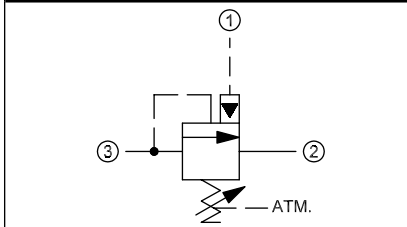
Symbol	Model No.	Cavity	Description	Flow*	Pressure	Page
	VDB 06-CN	NCS06/3	Unloading valve (atmospheric vent)	80 l/min [21 US gal/min]	350 bar [5000 psi]	06.27

* Flow ratings are based on a pressure drop of 7 bar [100 psi] unless otherwise noted. They are for comparison purposes only.

Cartridge Valves Technical Information

 Sequence valves
 Application notes

SEQUENCE VALVES

As the name implies, sequence valves control a sequence of operations. Sequence valves usually use a pressure signal to shift a spool, thereby opening or closing a flow path at a pre-set pressure.

Sequence valves



F102 013

DIRECT-ACTING
SEQUENCE VALVES

Direct-acting sequence valves are spool-type valves with a spring force holding the spool closed. When inlet pressure exceeds the spring setting, the spool shifts to direct flow to a second function.

Direct-acting sequence valves come in a variety of configurations:

- Internally-piloted with external drain
- Internally-piloted with internal drain
- Externally-piloted with internal drain

Direct-acting sequence valves are best suited for fairly constant flow and lower pressures.

Internal-pilot with external drain

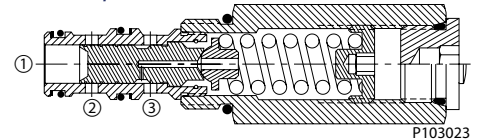

P103023

Internal-pilot with internal drain

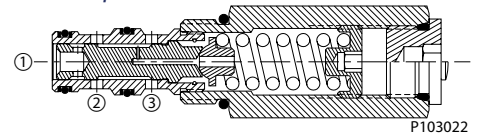

P103022

External-pilot with internal drain

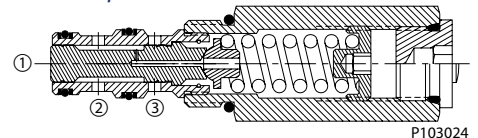

P103024

PILOT-OPERATED
SEQUENCE VALVES

Also available are pilot-operated sequence valves that have an internal pilot and an external drain.

Pilot-operated sequence valves are best suited for higher and more widely varying flows, and higher pressures.

Pilot operated sequence valve

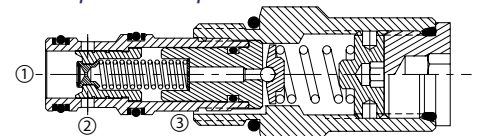

P103025

Cartridge Valves Technical Information

 Sequence valves
 Application notes

KICK-DOWN SEQUENCE VALVES

Another type of pilot-operated sequence valve is commonly known as a kick-down sequence valve. The kick-down sequence valve blocks flow at ① until sufficient pressure exists at ① to force the pilot poppet off its seat. This creates a pressure differential across the spool that causes the spool to shift and open flow from ① to ②. The spool will remain open until flow through the valve is shut off.

A common application for a kick-down sequence valve is as a safety device in circuits where overloading or overheating could cause damage if pressure is held for an extended period of time.

Kick-down sequence valve

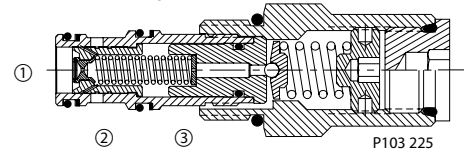

UNLOADING VALVES

Another type of sequence valve is commonly known as an unloading valve. The unloading valve blocks flow at ② until sufficient pressure exists at ① to pilot the poppet open against the pre-determined spring setting and allow flow from ② to ③. If the pressure at ① drops below the pilot ratio value multiplied by the pre-determined spring setting the valve will close, blocking flow at ②.

Various pilot ratio values are available; consult catalog sheets for details.

An unloading valve is typically used to *unload* a pump outlet to tank at a minimum pressure drop, resulting in higher system efficiencies with less heat generation.

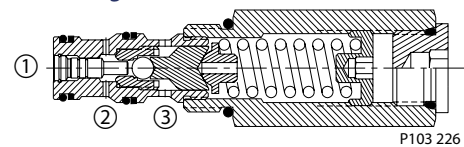
Unloading valve



APPLICATIONS

Unloading valves

Common applications for unloading valves include:

- Pump unloading in an accumulator charging system

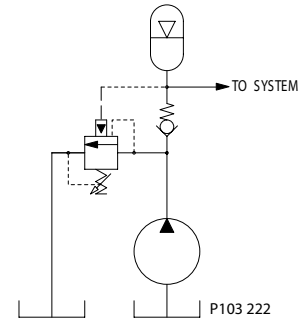
Accumulator charging/unloading valve

- For higher flow rates the unloading valve may be used to pilot a larger logic element

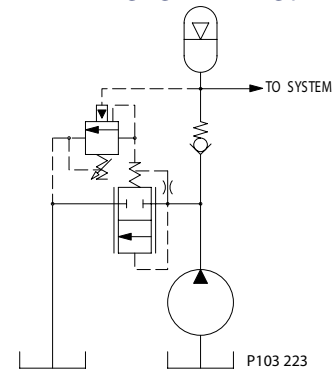
Accumulator charging/unloading pilot valve

- Pump unloading in a 2 pump high-low circuit

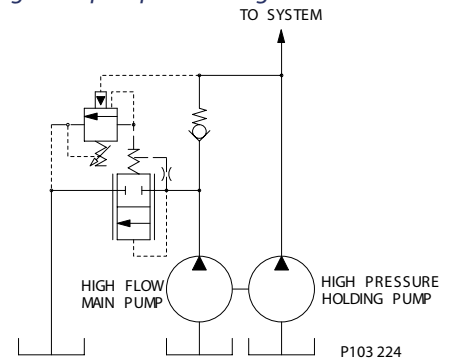
High-low pump unloading



Cartridge Valves Technical Information

Sequence valves

Application notes

APPLICATIONS (continued)

Sequence valves
Application notes

Sequence valves

Both direct-acting and pilot-operated sequence valves have many common applications

- Providing a sequenced series of operations such as in a clamp and lift circuit

Clamp & lift circuit

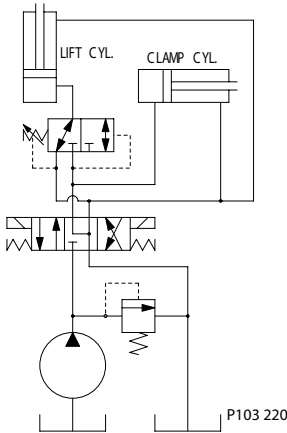

- Use as a relief valve where the return line has high or varying backpressure. The independent spring chamber drain line provides a relief setting unaffected by downstream pressure.

Sequence valve as relief

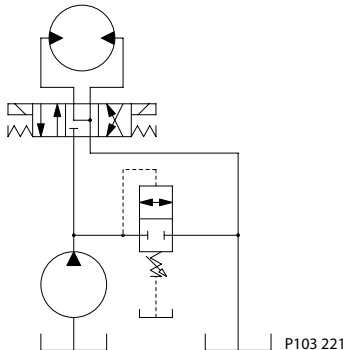



Cartridge Valves Technical Information

Sequence valves

CP240-8

OPERATION

Valve blocks flow from 1 to 2 until sufficient pressure is applied at 1

SPECIFICATIONS

Theoretical performance

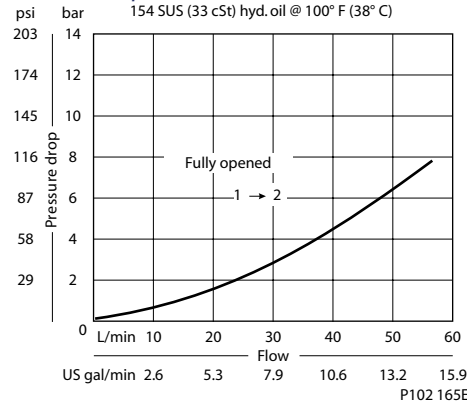

Schematic

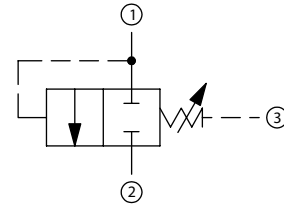

P102 164E

Specifications

Rated pressure	210 bar [3000 psi]
Rated flow at 7 bar [100 psi]	55 l/min [14 US gal/min]
Weight	0.26 kg [0.57 lb]
Cavity	SDC10-3

DIMENSIONS

mm [in]

Cross-sectional view

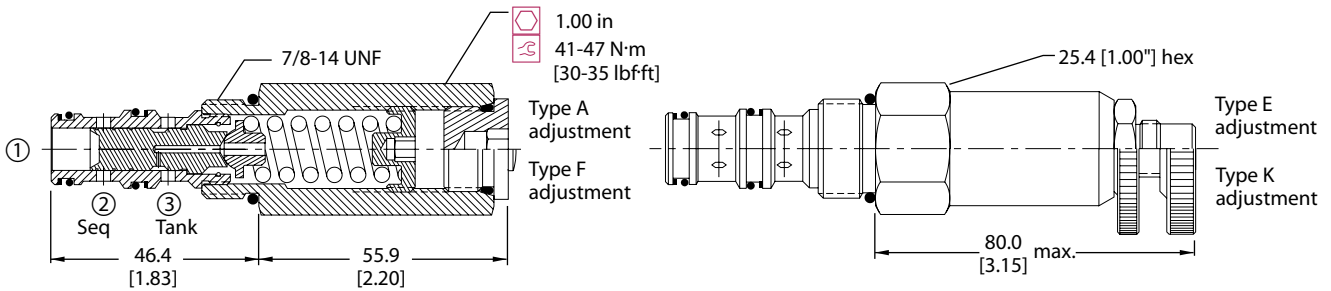

P102 163E

ORDERING INFORMATION

CP240 - 8 - B - 6S - A - C-050

Seals B = Buna-N V = Viton	Seal kit 120027 120028	Housing and ports 0 = No Housing SE3B = Al, 3/8 BSP SE4B = Al, 1/2 BSP 6S = Al, #6 SAE 8S = Al, #8 SAE Other housings available	Housing P/N No Housing SDC10-3-SE-3B SDC10-3-SE-4B CP10-3-6S CP10-3-8S	Adjustment option A = Internal E = External F = Tamper resistant K = Knob	Crack pressure Code x 10 = psi Example: 100 = 1000 psi	Pressure range <table border="0"> <tr> <td>A =</td> <td>4-28</td> <td>[psi]</td> <td>bar</td> </tr> <tr> <td>Std. setting</td> <td>17</td> <td>[50-400]</td> <td></td> </tr> <tr> <td>B =</td> <td>5-55</td> <td>[75-800]</td> <td></td> </tr> <tr> <td>Std. setting</td> <td>28</td> <td>[400]</td> <td></td> </tr> <tr> <td>C =</td> <td>7-97</td> <td>[100-1400]</td> <td></td> </tr> <tr> <td>Std. setting</td> <td>69</td> <td>[1000]</td> <td></td> </tr> <tr> <td>D =</td> <td>34-166</td> <td>[500-2400]</td> <td></td> </tr> <tr> <td>Std. setting</td> <td>103</td> <td>[1500]</td> <td></td> </tr> </table>	A =	4-28	[psi]	bar	Std. setting	17	[50-400]		B =	5-55	[75-800]		Std. setting	28	[400]		C =	7-97	[100-1400]		Std. setting	69	[1000]		D =	34-166	[500-2400]		Std. setting	103	[1500]	
A =	4-28	[psi]	bar																																			
Std. setting	17	[50-400]																																				
B =	5-55	[75-800]																																				
Std. setting	28	[400]																																				
C =	7-97	[100-1400]																																				
Std. setting	69	[1000]																																				
D =	34-166	[500-2400]																																				
Std. setting	103	[1500]																																				

P102 167E



Cartridge Valves Technical Information

Sequence valves

CP241-8

Sequence Valves
CP241-8

OPERATION

Valve blocks flow from 1 to 2 until sufficient pressure is applied at 1.

SPECIFICATIONS

Theoretical performance

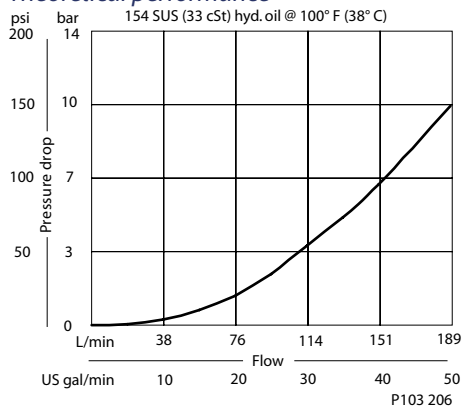

Schematic

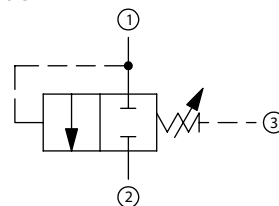

P102 164E

Specifications

Rated pressure	40 bar [600 psi]
Rated flow at 7 bar [100 psi]	150 l/min [39 US gal/min]
Weight	0.41 kg [0.90 lb]
Cavity	CP12-3S

DIMENSIONS

mm [in]

Cross-sectional view

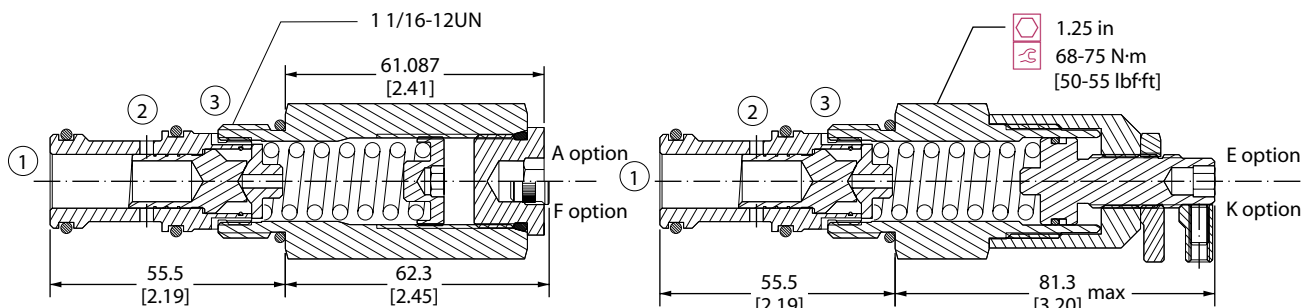

P102 626E

ORDERING INFORMATION

CP241-8-B-10S-A-C-050

<p>Seal kit 120680 120681</p>	<p>Pressure range A = 1-10 bar [13-150 psi] B = 3.4-28 bar [50-400 psi] C = 5.5-41 bar [80-600 psi]</p>	<p>Pressure setting Code x 10psi (0.69 bar) Example: 050 = 500 psi (35 bar)</p>
<p>Housing and ports 0 = No Housing 4B = Al, 1/2 BSP 6B = Al, 3/4 BSP 10S = Al, #10 SAE 12S = Al, #12 SAE Other housings available</p>	<p>Housing P/N No Housing CP12-3S-4B/2B CP12-3S-6B/2B CP12-3S-10S/4S CP12-3S-12S/4S</p>	<p>Adjustment option A = Internal E = External F = Tamper resistant K = Knob</p>

P102 632E



Cartridge Valves Technical Information

Sequence valves

CP240-21

OPERATION

Valve is a pilot-operated sequence valve that blocks flow from 1 to 2 until sufficient pressure is applied at 1.

SPECIFICATIONS

Theoretical performance

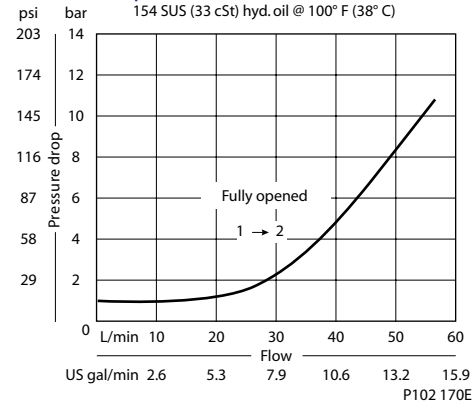

Schematic

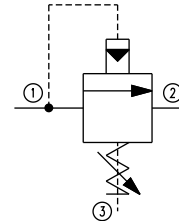

P102 168E

Specifications

Rated pressure	350 bar [5000 psi]
Rated flow at 7 bar [100 psi]	45 l/min [12 US gal/min]
Weight	0.23 kg [0.51 lb]
Cavity	SDC10-3

DIMENSIONS

mm [in]

Cross-sectional view

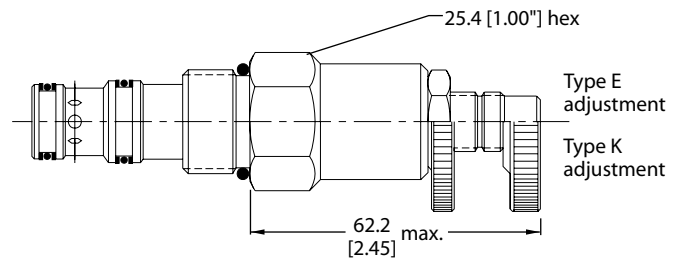
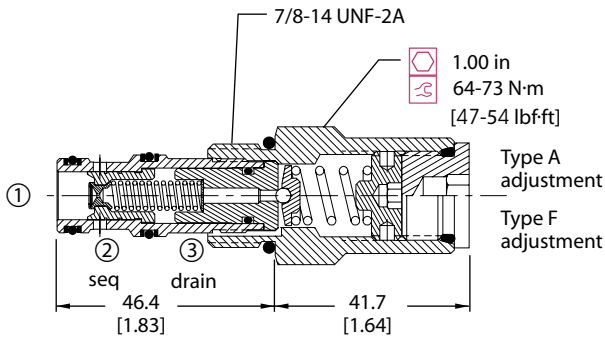

P102 169E

ORDERING INFORMATION

CP240 - 21 - B - 6S - A - C - 150

Seals
B = Buna-N
V = Viton

Seal kit
120009
120010

Housing and ports
0 = No Housing
SE3B = Al, 3/8 BSP
SE4B = Al, 1/2 BSP
6S = Al, #6 SAE
8S = Al, #8 SAE

Housing P/N
No Housing
SDC10-3-SE-3B
SDC10-3-SE-4B
CP10-3-6S
CP10-3-8S

Other housings available

Adjustment option
A = Internal
E = External
F = Tamper resistant
K = Knob

Crack pressure
Code x 10 = psi
Example: 150 = 1500 psi

Pressure range

	bar	[psi]
A	14-55	[200-800]
Std. setting	28	[400]
B	21-103	[300-1500]
Std. setting	69	[1000]
C	28-207	[400-3000]
Std. setting	103	[1500]
D	28-345	[400-5000]
Std. setting	103	[1500]

P102 172E



Cartridge Valves Technical Information

Sequence valves

CP241-21

Sequence Valves
CP241-21

OPERATION

Valve is a pilot-operated sequence valve that blocks flow from 1 to 2 until sufficient pressure is applied at 1.

SPECIFICATIONS

Theoretical performance

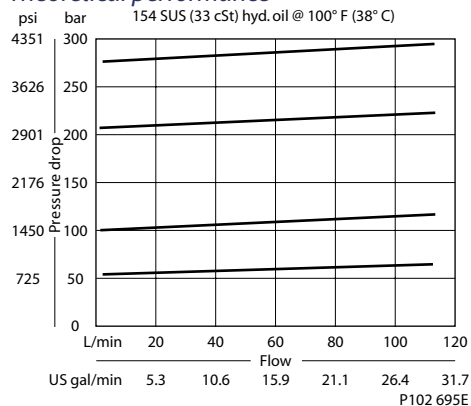

Schematic

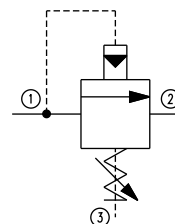

P102 168E

Specifications

Rated pressure	350 bar [5000 psi]
Rated flow at 7 bar [100 psi]	75 l/min [20 US gal/min]
Weight	0.17 kg [0.37 lb]
Cavity	CP12-3S

DIMENSIONS

mm [in]

Cross-sectional view

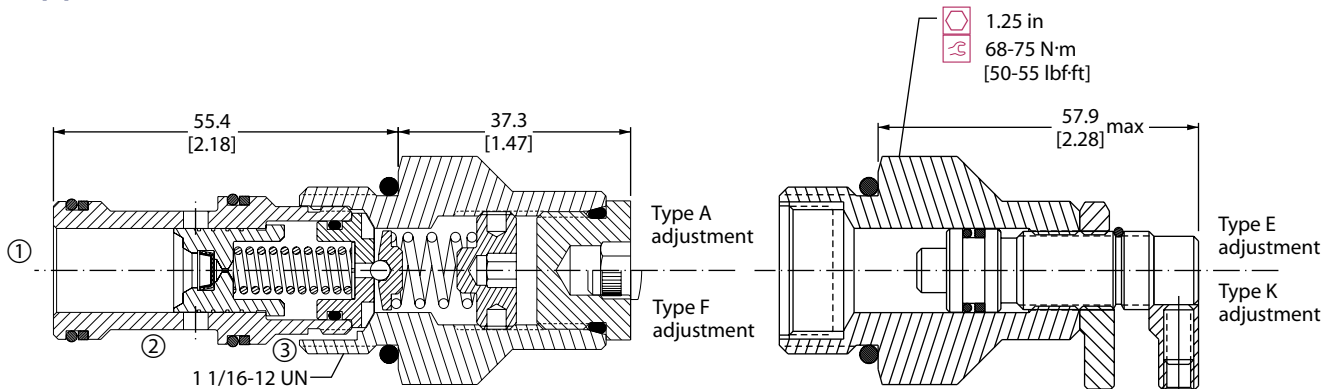

P102 696E

ORDERING INFORMATION

CP241 - 21 - B - 6S - A - C - 150

Seals B = Buna-N V = Viton	Seal kit 120335 120336	Housing and ports 0 = No Housing 4B = Al, 1/2 BSP 6B = Al, 3/4 BSP 10S = Al, #10 SAE 12S = Al, #12 SAE Other housings available	Housing P/N No Housing CP12-3S-4B/2B CP12-3S-6B/2B CP12-3S-10S/4S CP12-3S-12S/4S	Adjustment option A = Internal E = External F = Tamper resistant K = Knob	Crack pressure Code x 10 = psi Example: 150 = 1500 psi	Pressure range																								
						<table border="0"> <tr> <td>A =</td> <td>14-55</td> <td>[200-800]</td> </tr> <tr> <td>Standard</td> <td>28</td> <td>[400]</td> </tr> <tr> <td>B =</td> <td>21-103</td> <td>[300-1500]</td> </tr> <tr> <td>Standard</td> <td>69</td> <td>[1000]</td> </tr> <tr> <td>C =</td> <td>28-207</td> <td>[400-3000]</td> </tr> <tr> <td>Standard</td> <td>103</td> <td>[1500]</td> </tr> <tr> <td>D =</td> <td>28-345</td> <td>[400-5000]</td> </tr> <tr> <td>Standard</td> <td>103</td> <td>[1500]</td> </tr> </table>	A =	14-55	[200-800]	Standard	28	[400]	B =	21-103	[300-1500]	Standard	69	[1000]	C =	28-207	[400-3000]	Standard	103	[1500]	D =	28-345	[400-5000]	Standard	103	[1500]
A =	14-55	[200-800]																												
Standard	28	[400]																												
B =	21-103	[300-1500]																												
Standard	69	[1000]																												
C =	28-207	[400-3000]																												
Standard	103	[1500]																												
D =	28-345	[400-5000]																												
Standard	103	[1500]																												

P102 697E



Cartridge Valves Technical Information

Sequence valves

CP240-2

OPERATION

Valve blocks between 2 and 3 until sufficient pilot pressure is applied at 1 to open the valve. Note that pressure at 2 is additive to the spring setting.

SPECIFICATIONS

Theoretical performance

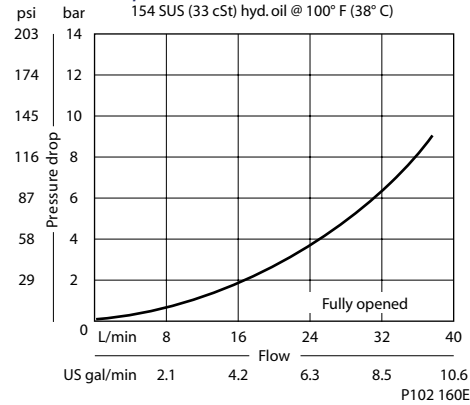

Schematic

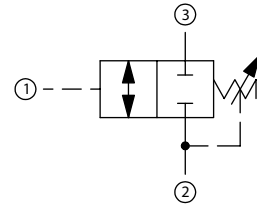

P102 159E

Specifications

Rated pressure	210 bar [3000 psi]
Rated flow at 7 bar [100 psi]	35 l/min [9 US gal/min]
Weight	0.24 kg [0.52 lb]
Cavity	SDC10-3

DIMENSIONS

mm [in]

Cross-sectional view

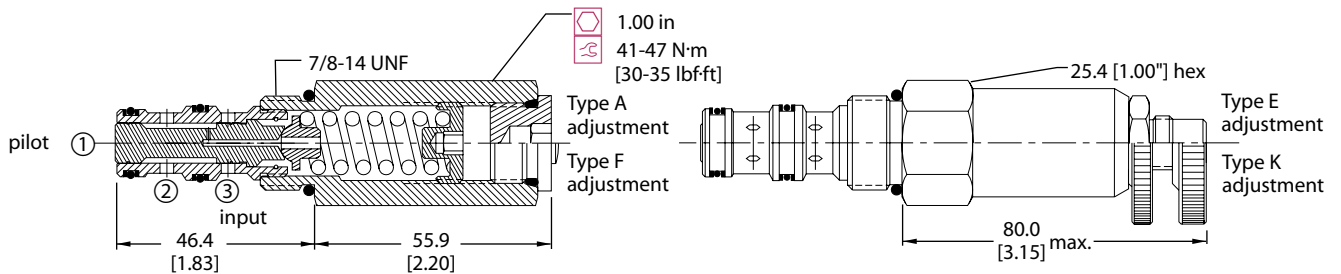

P102 158E

ORDERING INFORMATION

CP240 - 2 - B - 6S - A - C - 100

- Seals**
B = Buna-N
V = Viton
- Housing and ports**
0 = No Housing
SE3B = Al, 3/8 BSP
SE4B = Al, 1/2 BSP
6S = Al, #6 SAE
8S = Al, #8 SAE
Other housings available
- Adjustment option**
A = Internal
E = External
F = Tamper resistant
K = Knob
- Seal kit**
120009
120010
- Housing P/N**
No Housing
SDC10-3-SE-3B
SDC10-3-SE-4B
CP10-3-6S
CP10-3-8S
- Crack pressure**
Code x 10 = psi
Example: 100 = 1000 psi
- Pressure range**
bar [psi]
A = 4-28 [50-400]
Std. setting 17 [250]
B = 5-55 [75-800]
Std. setting 28 [400]
C = 7-97 [100-1400]
Std. setting 69 [1000]
D = 34-166 [500-2400]
Std. setting 103 [1500]

P102 162E



Cartridge Valves Technical Information

Sequence valves

VDP 06/NA

Sequence Valves
VDP 06/NA

OPERATION

This is a direct-acting, normally-open, spool-type sequence valve with external pilot and atmospheric vent.

SPECIFICATIONS

Theoretical performance

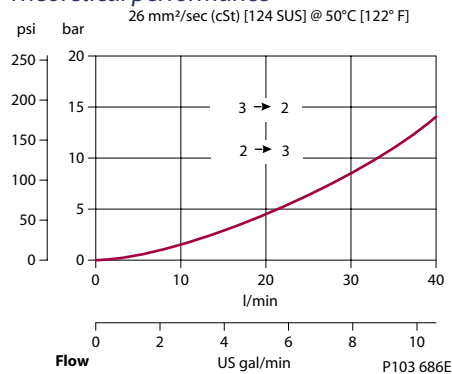

Schematic

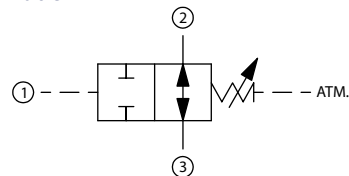

P103 521

Specifications

Rated pressure	315 bar [4500 psi]
Rated flow at 7 bar [100 psi]	25 l/min [7 US gal/min]
Weight	0.26 kg [0.57 lb]
Cavity	NCS06/3

DIMENSIONS

mm [in]

Cross-sectional view

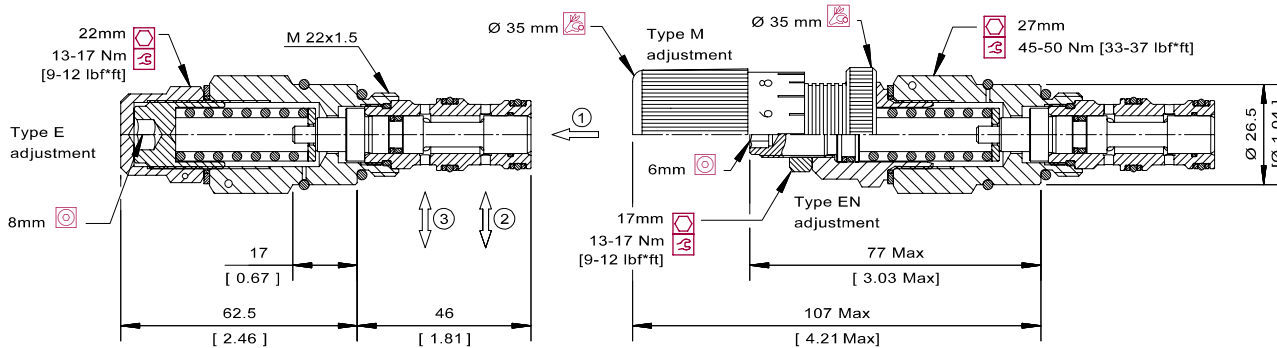

P103 659

ORDERING INFORMATION

VDP 06 / NA - EN - 1 - 00 - V

Type of adjustment

E = Internal screw
EN = External screw
M = Handwheel

Setting range

1 = 15-40 bar [217-580 psi]
2 = 30-120 bar [435-3046 psi]
3 = 105-190 bar [1523-2756 psi]

To order this valve with a specific factory setting, contact your Sauer-Danfoss representative

Seals

V = Viton 230000110
Omit = Buna-N 230000070

Housing and ports

00 = No Housing
SE3/8 = AL, 3/8 BSP
SE1/2 = AL, 1/2 BSP
SE6S = AL, #6 SAE
SE8S = AL, #8 SAE
Other housings available

Seal kit

No Housing
NCS06/3-SE-3/8
NCS06/3-SE-1/2
NCS06/3-SE-6S
NCS06/3-SE-8S

P103 713E



Cartridge Valves Technical Information

Sequence valves

VDP 06/NC

OPERATION

This is a direct-acting, normally-closed, spool-type sequence valve with external pilot and atmospheric vent.

SPECIFICATIONS

Theoretical performance

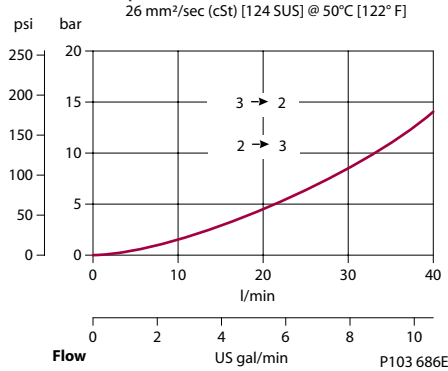

Schematic

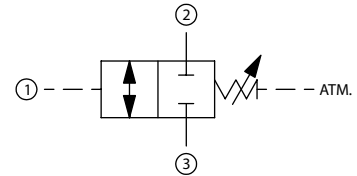

P103 528

Specifications

Rated pressure	315 bar [4500 psi]
Rated flow at 7 bar [100 psi]	25 l/min [7 US gal/min]
Weight	0.26 kg [0.57 lb]
Cavity	NCS06/3

DIMENSIONS

mm [in]

Cross-sectional view

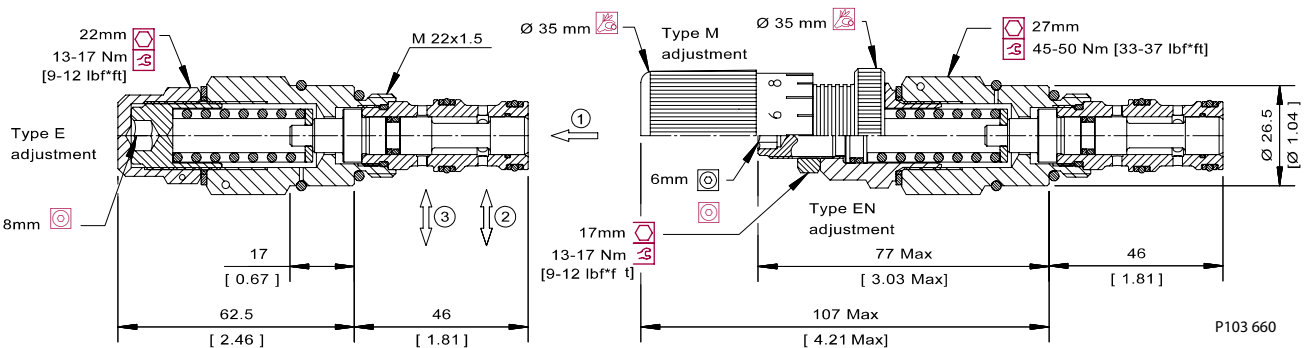

ORDERING INFORMATION

VDP 06 / NC - EN - 1 - 00 - V

Adjustment

- E = Internal screw
- EN = External screw
- M = Handwheel

Setting range

- 1 = 15-40 bar [217-580 psi]
- 2 = 30-120 bar [435-1740 psi]
- 3 = 105-190 bar [1523-2756 psi]

Seals

- V = Viton
- Omit = Buna-N

Housing and ports

- 00 = No Housing
- SE3/8 = AL, 3/8 BSP
- SE1/2 = AL, 1/2 BSP
- SE6S = AL, #6 SAE
- SE8S = AL, #8 SAE
- Other housings available

Seal kit

- 230000110
- 230000070

Housing P/N

- No Housing
- NCS06/3-SE-3/8
- NCS06/3-SE-1/2
- NCS06/3-SE-6S
- NCS06/3-SE-8S

To order this valve with a specific factory setting, contact your Sauer-Danfoss representative

P103 714E



Cartridge Valves Technical Information

Sequence valves

CP240-5

Sequence Valves
CP240-5

OPERATION

Valve allows flow between 2 and 3 until sufficient pressure is applied at 1 to close the valve. Note that pressure at 4 is additive to the spring setting.

SPECIFICATIONS

Theoretical performance

33 cSt [154 SUS] hyd.oil @ 38°C [100° F]

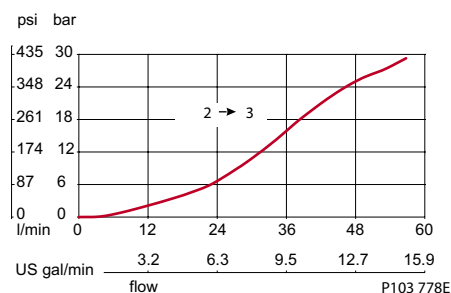

Schematic

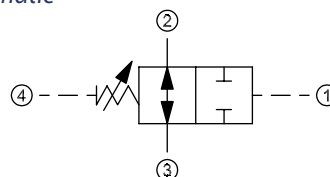

P103 520

Specifications

Rated pressure	210 bar [3000 psi]
Rated flow at 7 bar [100 psi]	25 l/min [7 US gal/min]
Weight	0.26 kg [0.57 lb]
Cavity	SDC10-4

DIMENSIONS

mm [in]

Cross-sectional view

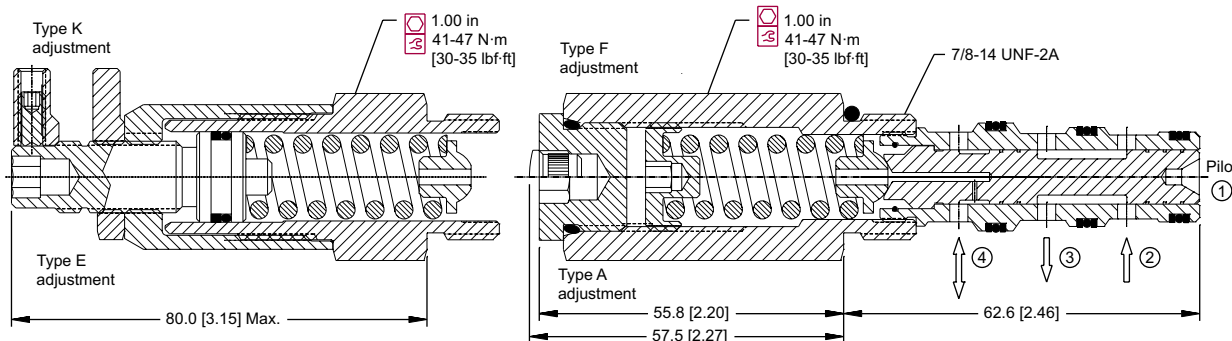

P103 745

ORDERING INFORMATION

CP240-5-V-L3B-A-B-050

<p>Seals</p> <p>Seal kit</p> <p>B = Buna-N 120023</p> <p>V = Viton 120024</p>	<p>Housing and ports</p> <p>0 = No Housing</p> <p>L3B = AL, 3/8 BSP</p> <p>L4B = AL, 1/2 BSP</p> <p>6S = AL, #6 SAE</p> <p>8S = AL, #8 SAE</p> <p>Other housings available</p>	<p>Housing P/N</p> <p>No Housing SDC10-4-L-3B</p> <p>SDC10-4-L-4B</p> <p>SDC10-4-6S</p> <p>SDC10-4-8S</p>	<p>Sequence Pressure</p> <p>Code x 0.69 = bar</p> <p>[Code x 10 = psi]</p> <p>Example: 050 = 34.5 bar [500 psi]</p> <p>Pressure range</p> <table border="0"> <tr><td>bar</td><td>[psi]</td></tr> <tr><td>A = 3.4 - 27.6</td><td>[50 - 400]</td></tr> <tr><td>B = 4.8 - 55.2</td><td>[70 - 800]</td></tr> <tr><td>C = 6.9 - 96.5</td><td>[100 - 1400]</td></tr> <tr><td>D = 34.5 - 165.5</td><td>[500 - 2400]</td></tr> </table> <p>Adjustment option</p> <p>A = Internal</p> <p>E = External</p> <p>F = Tamper resistant</p> <p>K = Knob</p>	bar	[psi]	A = 3.4 - 27.6	[50 - 400]	B = 4.8 - 55.2	[70 - 800]	C = 6.9 - 96.5	[100 - 1400]	D = 34.5 - 165.5	[500 - 2400]
bar	[psi]												
A = 3.4 - 27.6	[50 - 400]												
B = 4.8 - 55.2	[70 - 800]												
C = 6.9 - 96.5	[100 - 1400]												
D = 34.5 - 165.5	[500 - 2400]												

P103 779E



Cartridge Valves Technical Information

Sequence valves

VDP 06/42 01

OPERATION

This is a direct-acting, spool-type sequence valve with external pilot and atmospheric vent.

SPECIFICATIONS

Theoretical performance

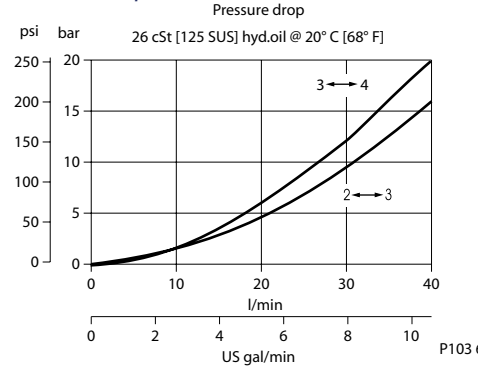

Schematic

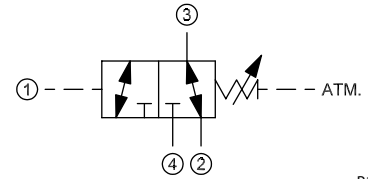

P103 527

Specifications

Rated pressure	315 bar [4500 psi]
Rated flow at 7 bar [100 psi]	22 l/min [6 US gal/min]
Weight	0.28 kg [0.62 lb]
Cavity	NCS06/4

DIMENSIONS

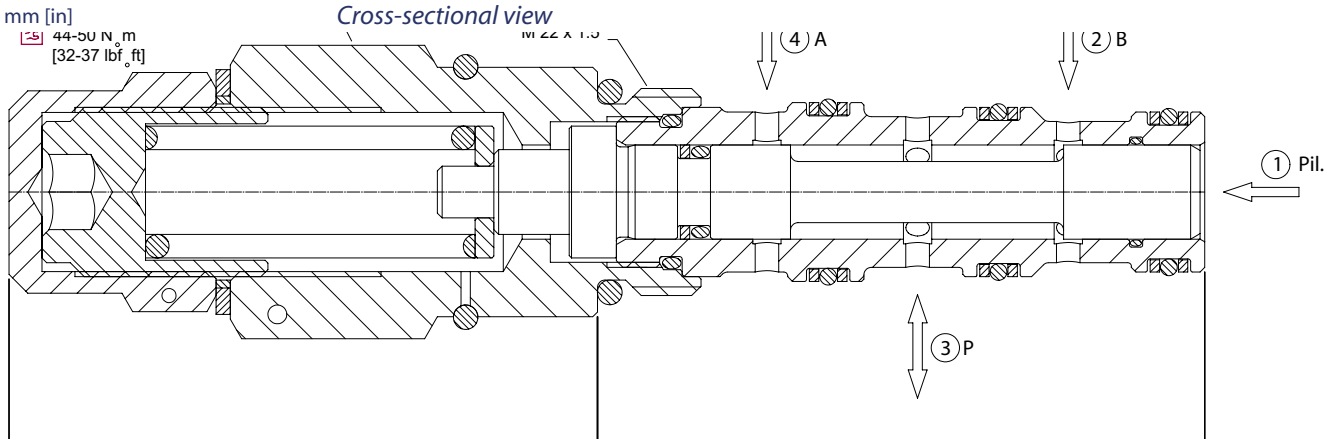

ORDERING INFORMATION

VDP 06 / 42 01 - M - 1 - 00 - V

Adjustment
E = Internal screw
EN = External screw
M = Handwheel

Setting range
1 = 15 - 40 bar [220-580 psi]
2 = 30 - 120 bar [430-1740 psi]
3 = 105 - 190 bar [1520-2750 psi]

Seals
V = Viton
Omit = Buna-N

Housing and ports
00 = No Housing
L3/8 = AL, 3/8 BSP
L1/2 = AL, 1/2 BSP
L6S = AL, #6 SAE
L8S = AL, #8 SAE
Other housings available

Seal kit
230000350
230000080

Housing P/N
No Housing
NCS06/4-L-3/8
NCS06/4-L-1/2
NCS06/4-L-6S
NCS06/4-L-8S

To order this valve with a specific factory setting, contact your Sauer-Danfoss representative

P103 712E



Cartridge Valves Technical Information

Sequence valves

CP240-1

Sequence Valves
CP240-1

OPERATION

This valve is a direct acting, spool type sequence valve with internal pilot. This valve allows flow from 2 to 3 and blocks 1. At reaching the sequence pressure 1 is opened to 2.

SPECIFICATIONS

Theoretical performance

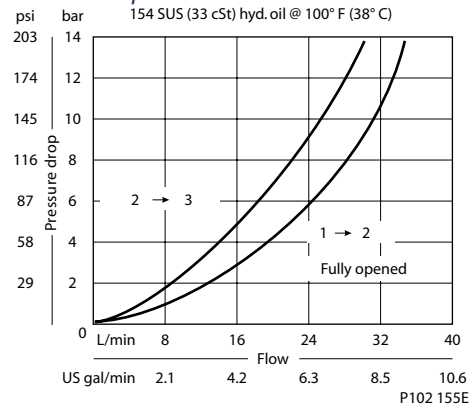

Schematic

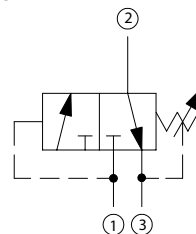

P102 153E

Specifications

Rated pressure	210 bar [3000 psi]
Rated flow at 7 bar [100 psi]	25 l/min [7 US gal/min]
Weight	0.25 kg [0.56 lb]
Cavity	SDC10-3

DIMENSIONS

mm [in]

Cross-sectional view

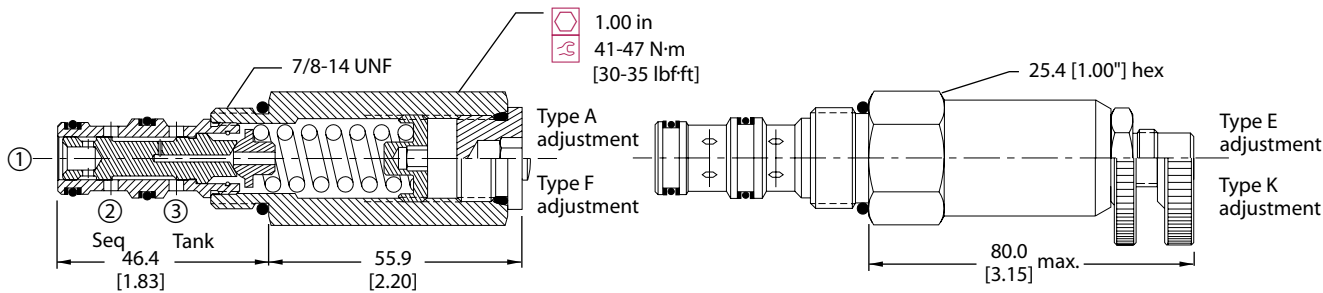

P102 154E

ORDERING INFORMATION

CP240 - 1 - B - 6S - A - C - 100

- Seals**
 - B = Buna-N
 - V = Viton
- Seal kit**
 - 120009
 - 120010
- Housing and ports**
 - 0 = No Housing
 - SE3B = Al, 3/8 BSP
 - SE4B = Al, 1/2 BSP
 - 6S = Al, #6 SAE
 - 8S = Al, #8 SAE
 - Other housings available
- Housing P/N**
 - No Housing
 - SDC10-3-SE-3B
 - SDC10-3-SE-4B
 - CP10-3-6S
 - CP10-3-8S
- Adjustment option**
 - A = Internal
 - E = External
 - F = Tamper resistant
 - K = Knob
- Crack pressure**
 - Code x 10 = psi
 - Example: 100 = 1000 psi
- Pressure range**
 - A = bar [psi]
 - Std. setting 4-28 [50-400]
 - B = 17 [250]
 - Std. setting 5-55 [75-800]
 - C = 28 [400]
 - Std. setting 7-97 [100-1400]
 - D = 69 [1000]
 - Std. setting 34-166 [500-2400]
 - E = 103 [1500]

P102 157E



Cartridge Valves Technical Information

Sequence valves VDP 06/32 01

OPERATION

This is a direct-acting, spool-type sequence valve with internal pilot. This valve allows flow between 2 and 3 and blocks 1. At reaching the sequence pressure, 1 is opened to 2. Note that pressure at 3 is additive to the spring setting.

SPECIFICATIONS

Theoretical performance

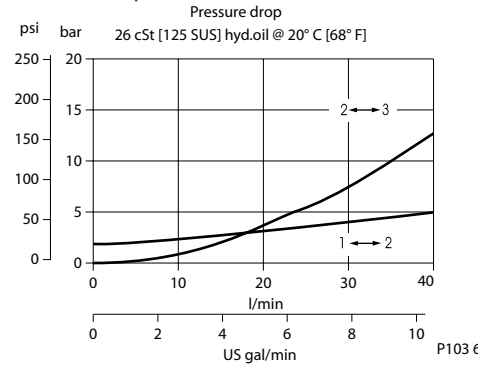

Schematic

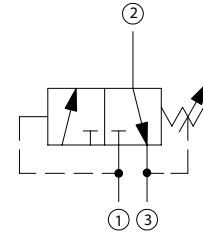

P102 153E

Specifications

Rated pressure	315 bar [4500 psi]
Rated flow at 7 bar [100 psi]	30 l/min [8 US gal/min]
Weight	0.21 kg [0.46 lb]
Cavity	NCS06/3

DIMENSIONS

mm [in]

Cross-sectional view

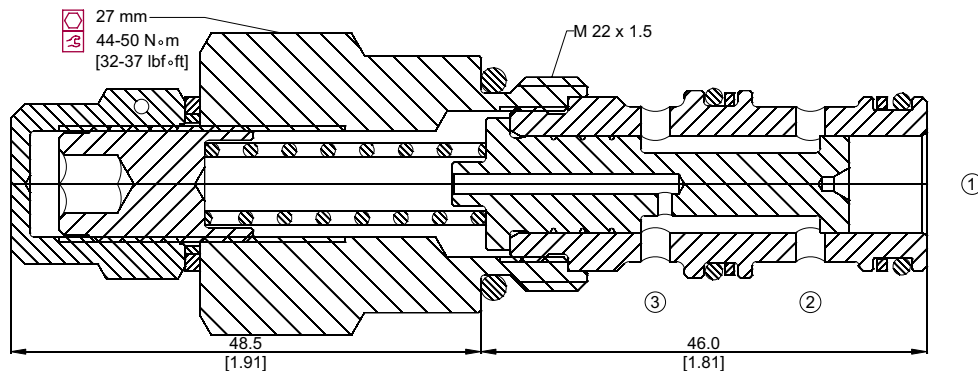

P103 657

ORDERING INFORMATION

VDP 06/32 01 - M - 1 - 00 - V

Adjustment

- E = Internal screw
- EN = External screw
- M = Handwheel

Setting range

- 1 = 5-17 bar [73-240 psi]
- 2 = 10-30 bar [145-435 psi]
- 3 = 20-40 bar [290-580 psi]

Seals

- V = Viton
- Omit = Buna-N

Housing and ports

- 00 = No Housing
- SE3/8 = AL, 3/8 BSP
- SE1/2 = AL, 1/2 BSP
- SE6S = AL, #6 SAE
- SE8S = AL, #8 SAE
- Other housings available

Seal kit

- 230000110
- 230000070

Housing P/N

- No Housing
- NCS06/3-SE-3/8
- NCS06/3-SE-1/2
- NCS06/3-SE-6S
- NCS06/3-SE-8S

To order this valve with a specific factory setting, contact your Sauer-Danfoss representative

P103 711E



Cartridge Valves Technical Information

Sequence valves

VDB 12-CN

Sequence Valves
VDB 12-CN

OPERATION

This is a pilot-operated, atmospherically-vented, unloading valve.

SPECIFICATIONS

Theoretical performance

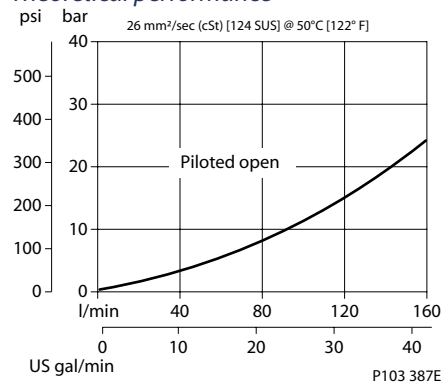

Schematic

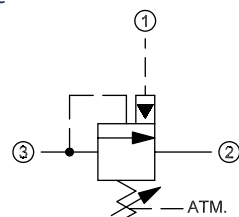

P103 523

Specifications

Rated pressure	350 bar [5000 psi]
Rated flow at 7 bar [100 psi]	160 l/min [42 US gal/min]
Weight	0.93 kg [2.05 lb]
Cavity	NCS12/3

DIMENSIONS

mm [in]

Cross-sectional view

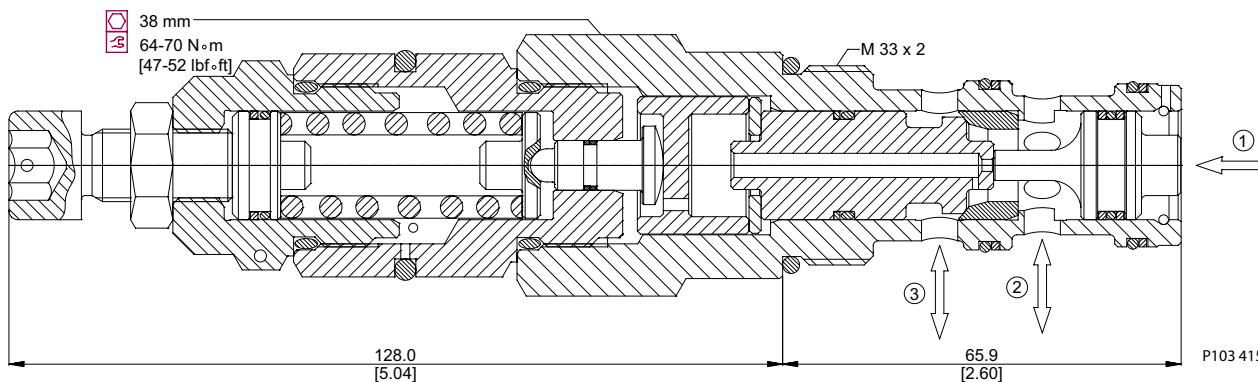

ORDERING INFORMATION

VDB 12-CN - 2 - A - 00 - V

Setting range

Pilot ratio A	Pilot ratio B
1 = 25 - 170 bar [363-2466 psi]	1 = 25 - 120 bar [363-1740 psi]
2 = 70 - 250 bar [1015-3626 psi]	2 = 60 - 200 bar [870-2900 psi]
3 = 105 - 350 bar [1523-5076 psi]	3 = 90 - 280 bar [1305-4061 psi]

Pilot ratio

A = 6.9 : 1
B = 4.7 : 1

Seals

V = Viton
Omit = Buna-N

Housing and ports

00 = No Housing
SE1/2 = AL, 1/2 BSP
SE3/4 = AL, 3/4 BSP
SE8S = AL, #8 SAE
SE12S = AL, #12 SAE
Other housings available

Seal kit

230000360
230000130

Housing P/N

No Housing
NCS12/3-SE-1/2
NCS12/3-SE-3/4
NCS12/3-SE-8S
NCS12/3-SE-12S

To order this valve with a specific factory setting, contact your Sauer-Danfoss representative

P103 416E



Cartridge Valves Technical Information

Sequence valves

CP240-9

OPERATION

This valve drains 3 to 2 when the pressure at 1 is below the spring setting, and connects 1 to 2 when the pressure at 1 exceeds the spring setting. Note that pressure at 2 is additive to the spring setting.

SPECIFICATIONS

Theoretical performance

33 cSt [154 SUS] hyd.oil @ 38°C [100° F]

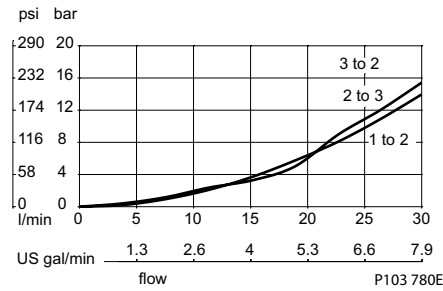

Schematic

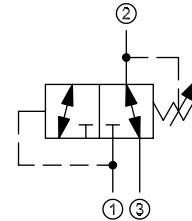

P103 526

Specifications

Rated pressure	210 bar [3000 psi]
Rated flow at 7 bar [100 psi]	20 l/min [5 US gal/min]
Weight	0.24 kg [0.52 lb]
Cavity	SDC10-3

DIMENSIONS

mm [in]

Cross-sectional view

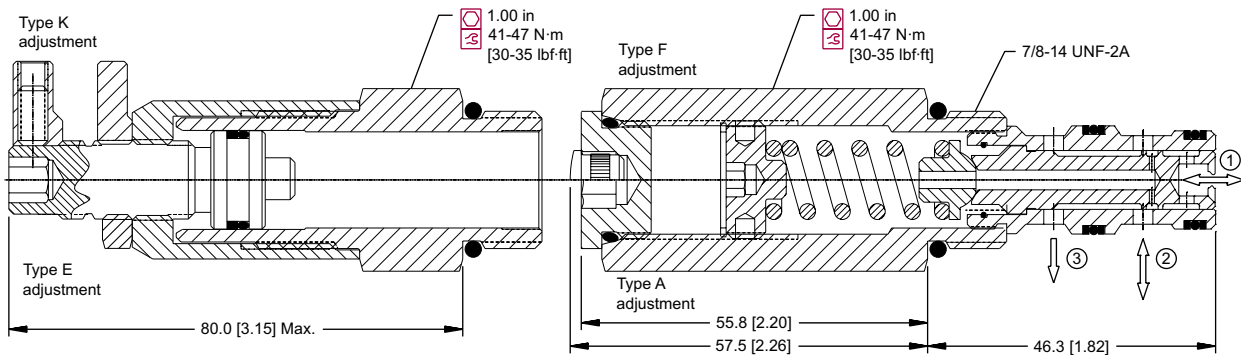

P103 746

ORDERING INFORMATION

CP240-9-B-6S-E-A-020

Seals	Seal kit	Crack Pressure
B = Buna-n	120009	Code x 0.69 = bar
V = Viton	120010	[Code x 10 = psi]
		Example: 020 = 14 bar [200 psi]
Housing and ports	Housing P/N	Pressure range
0 = No Housing	No Housing	bar [psi]
SE3B = AI, 3/8 BSP	SDC10-3-SE-3B	A = 6.9 - 27.6 [100 - 400]
SE4B = AI, 1/2 BSP	SDC10-3-SE-4B	B = 20.7 - 55.2 [300 - 800]
6S = AI, #6 SAE	CP10-3-6S	C = 20.7 - 96.5 [300 - 1400]
8S = AI, #8 SAE	CP10-3-8S	D = 68.9 - 165.5 [1000 - 2400]
Other housings available		Adjustment option
		A = Internal
		E = External
		F = Tamper resistant
		K = Knob

P103 781E



Cartridge Valves Technical Information

Sequence valves

CP240-30

Sequence Valves
CP240-30

OPERATION

This is a normally-closed sequence valve that loads and unloads a system at a pre-determined ratio.

SPECIFICATIONS

Theoretical performance

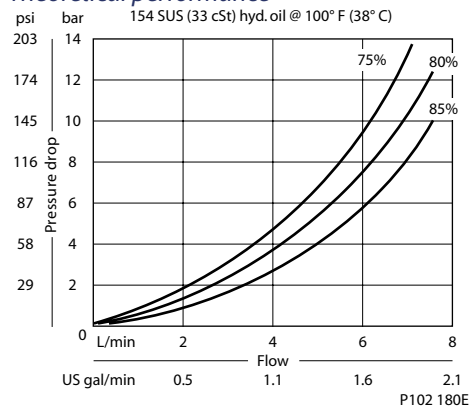

Schematic

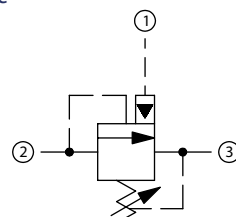

P102 178E

Specifications

Rated pressure	210 bar [3000 psi]
Rated flow at 7 bar [100 psi]	4 l/min [1 US gal/min]
Weight	0.24 kg [0.53 lb]
Cavity	SDC10-3

DIMENSIONS

mm [in]

Cross-sectional view

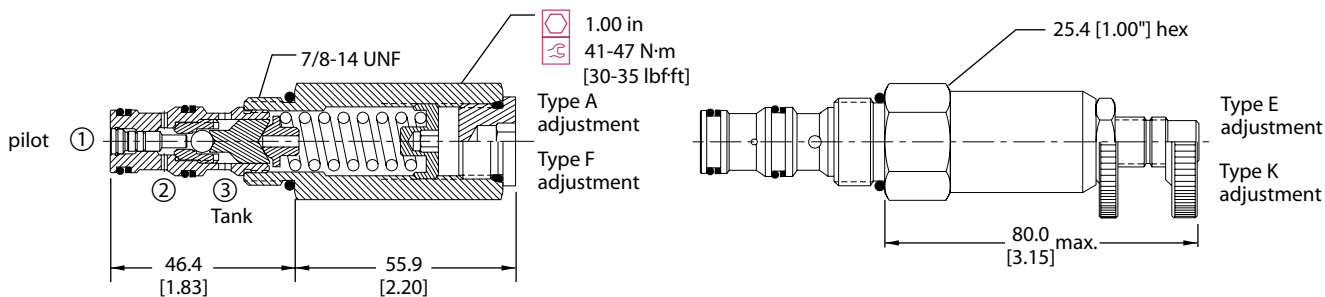

P102 179E

ORDERING INFORMATION

CP240 - 30 - B - 6S - A - B - 75-150

- Seals**
 - B = Buna-N
 - V = Viton
- Seal kit**
 - 120027
 - 120028
- Housing and ports**
 - 0 = No Housing
 - SE3B = Al, 3/8 BSP
 - SE4B = Al, 1/2 BSP
 - 6S = Al, #6 SAE
 - 8S = Al, #8 SAE
- Housing P/N**
 - No Housing
 - SDC10-3-SE-3B
 - SDC10-3-SE-4B
 - CP10-3-6S
 - CP10-3-8S
- Adjustment option**
 - A = Internal
 - E = External
 - F = Tamper resistant
 - K = Knob
- Crack pressure**
 - Code x 10 = psi
 - Example: 150 = 1500 psi
- Pressure ratio**
 - 75 = 75%
 - 80 = 80%
 - 85 = 85%
- Pressure range**

Code	bar	[psi]
A	34-138	[500-2000]
Std. setting	69	[1000]
B	62-207	[900-3000]
Std. setting	103	[1500]

P102 182E



Cartridge Valves Technical Information

Sequence valves

AUV06

OPERATION

This is a normally-closed sequence valve that loads and unloads a system at a pre-determined ratio.

SPECIFICATIONS

Theoretical performance

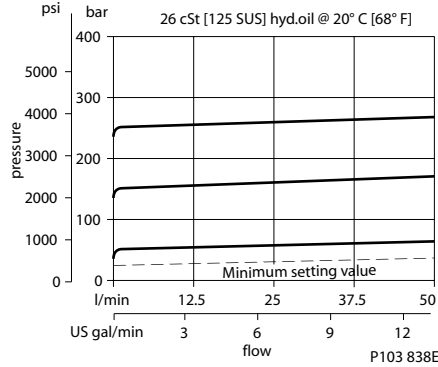

Schematic

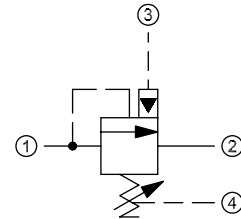

P103 519

Specifications

Rated pressure	250 bar [3600 psi]
Rated flow at 7 bar [100 psi]	50 l/min [13 US gal/min]
Weight	0.22 kg [0.49 lb]
Cavity	NCS06/4

DIMENSIONS

mm [in]

Cross-sectional view

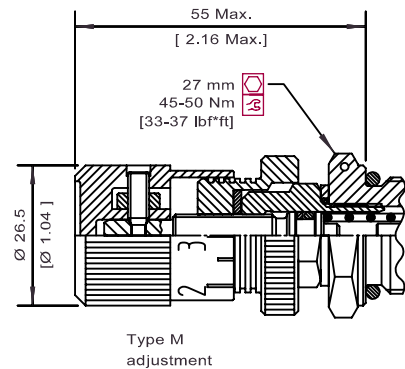
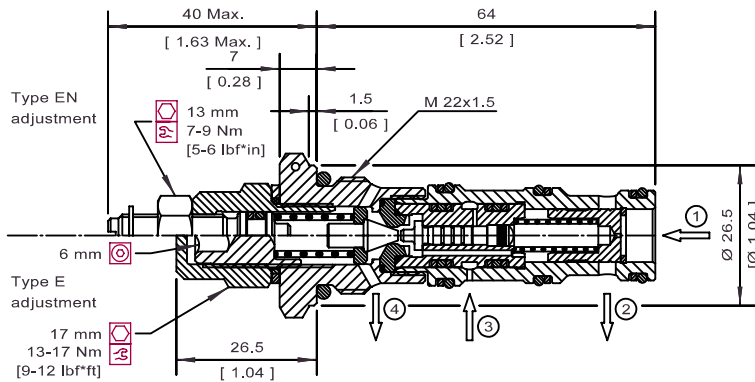

P103 898E

ORDERING INFORMATION

AUV 06 - EN - 1 - A - L3/8 - V

Adjustment

E = Internal screw
EN = External screw
M = Handwheel

Setting range

1 = 10-70 bar [145-1015 psi]
2 = 30-140 bar [435-2031 psi]
3 = 70-210 bar [1015-3046 psi]

Pressure ratio

A = 85%

Seals

V = Viton
Omit = Buna-N

Seal kit

230000350
230000080

Housing and ports

00 = No Housing
L3/8 = AL, 3/8 BSP
L1/2 = AL, 1/2 BSP
L6S = AL, #6 SAE
L8S = AL, #8 SAE
Other housings available

Housing P/N

No Housing
NCS06/4-L-3/8
NCS06/4-L-1/2
NCS06/4-L-6S
NCS06/4-L-8S

To order this valve with a specific factory setting, contact your Sauer-Danfoss representative P103 839E



Cartridge Valves Technical Information
Sequence valves
VDB 06-EN

Sequence valves
VDB 06-EN

OPERATION

This is a pilot-operated unloading valve.

SPECIFICATIONS

Theoretical performance

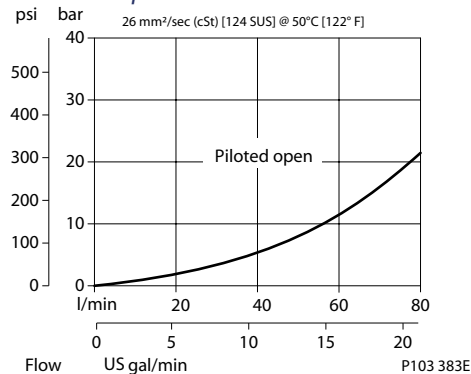

Schematic

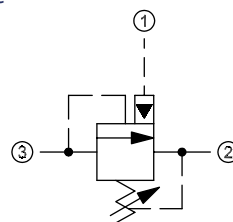

P103 522

Specifications

Rated pressure	350 bar [5000 psi]
Rated flow at 7 bar [100 psi]	80 l/min [21 US gal/min]
Weight	0.21 kg [0.46 lb]
Cavity	NCS06/3

DIMENSIONS

mm [in]

Cross-sectional view

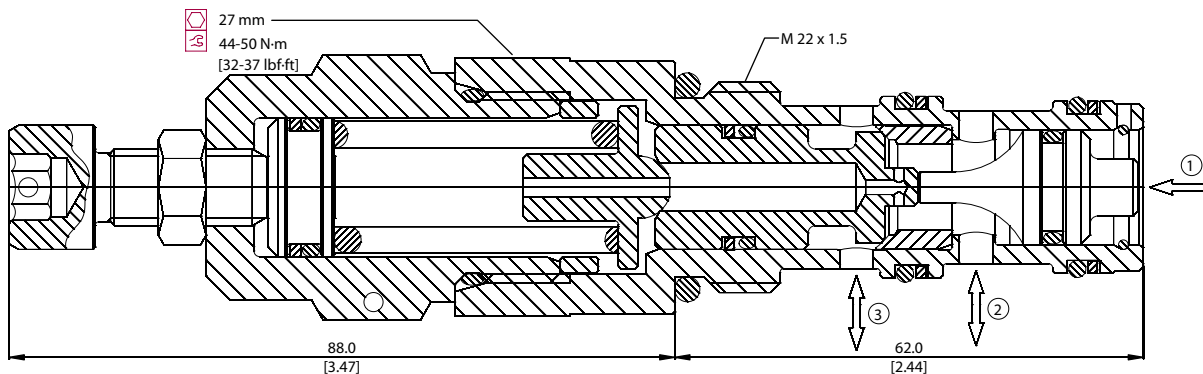

P103 409

ORDERING INFORMATION

VDB 06-EN - 2 - A - SE3/8 - V

Setting range

- 1 = 25 - 140 bar [362 - 2031 psi]
- 2 = 70 - 210 bar [1015 - 3046 psi]
- 3 = 105 - 350 bar [1523 - 5076 psi]

Pilot ratio

- A = 7.1 : 1
- B = 4.1 : 1
- E = 1 : 1

To order this valve with a specific factory setting, contact your Sauer-Danfoss representative

Seals

- V = Viton
- Omit = Buna-N

Seal kit

- 230000110
- 230000070

Housing and ports

- 00 = No Housing
- SE3/8 = AL, 3/8 BSP
- SE1/2 = AL, 1/2 BSP
- SE6S = AL, #6 SAE
- SE8S = AL, #8 SAE
- Other housings available

Housing P/N

- No Housing
- NCS06/3-SE-3/8
- NCS06/3-SE-1/2
- NCS06/3-SE-6S
- NCS06/3-SE-8S

P103 384E



Cartridge Valves Technical Information

Sequence valves

VDB 12-EN

OPERATION

This is a pilot-operated unloading valve.

SPECIFICATIONS

Theoretical performance

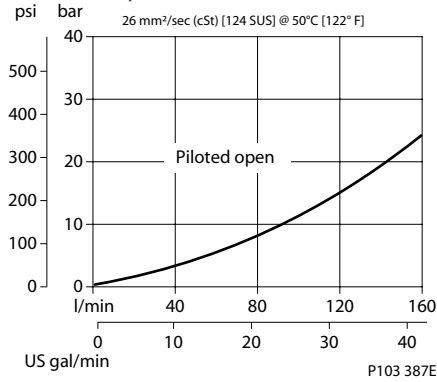

Schematic

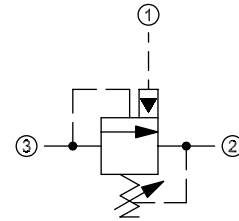

P103 522

Specifications

Rated pressure	350 bar [5000 psi]
Rated flow at 7 bar [100 psi]	160 l/min [42 US gal/min]
Weight	0.70 kg [1.54 lb]
Cavity	NCS12/3

DIMENSIONS

mm [in]

Cross-sectional view

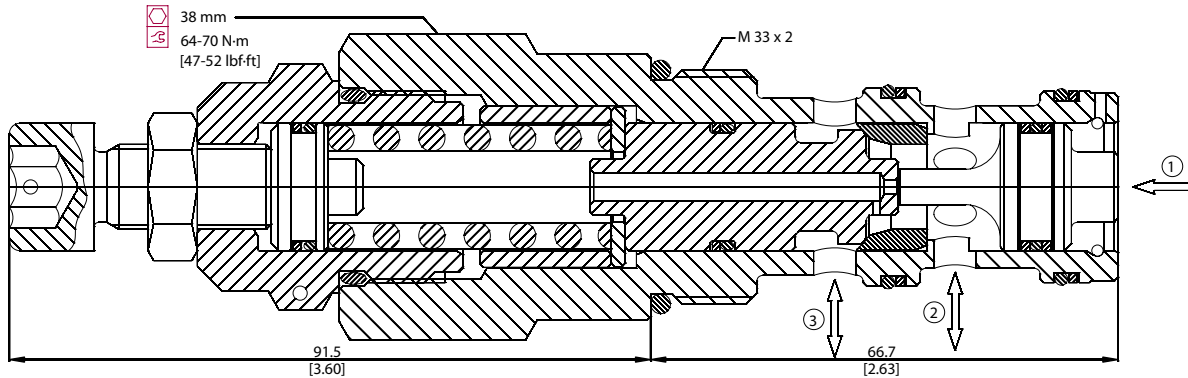

P103 417

ORDERING INFORMATION

VDB 12-EN - 2 - A - 00 - V

Setting range

Pilot ratio A

- 1 = 25 - 170 bar [363-2466 psi]
- 2 = 70 - 250 bar [1015-3626 psi]
- 3 = 105 - 350 bar [1523-5076 psi]

Pilot ratio B

- 1 = 25 - 120 bar [363-1740 psi]
- 2 = 60 - 200 bar [870-2900 psi]
- 3 = 90 - 280 bar [1305-4061 psi]

Pilot ratio

- A = 6.9 : 1
- B = 4.7 : 1

Seals

- V = Viton
- Omit = Buna-N

Housing and ports

- 00 = No Housing
- SE1/2 = AL, 1/2 BSP
- SE3/4 = AL, 3/4 BSP
- SE8S = AL, #8 SAE
- SE12S = AL, #12 SAE
- Other housings available

Seal kit

- 230000360
- 230000130

Housing P/N

- No Housing
- NCS12/3-SE-1/2
- NCS12/3-SE-3/4
- NCS12/3-SE-8S
- NCS12/3-SE-12S

To order this valve with a specific factory setting, contact your Sauer-Danfoss representative

P103 388E



Cartridge Valves Technical Information

Sequence valves

CP240-22

Sequence Valves
CP240-22

OPERATION

This is a "kick-down" type sequence valve that blocks flow from 1 to 2 until sufficient pressure is applied at 1. Once open, the valve remains open until flow is completely shut off.

SPECIFICATIONS

Theoretical performance

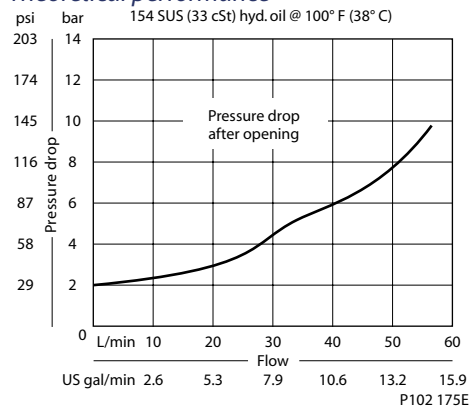

Schematic

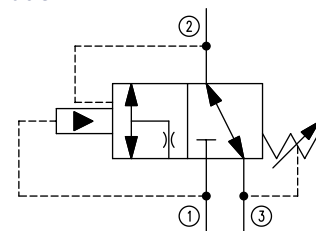

P102 173E

Specifications

Rated pressure	350 bar [5000 psi]
Rated flow at 7 bar [100 psi]	45 l/min [12 US gal/min]
Weight	0.19 kg [0.42 lb]
Cavity	SDC10-3

DIMENSIONS

mm [in]

Cross-sectional view

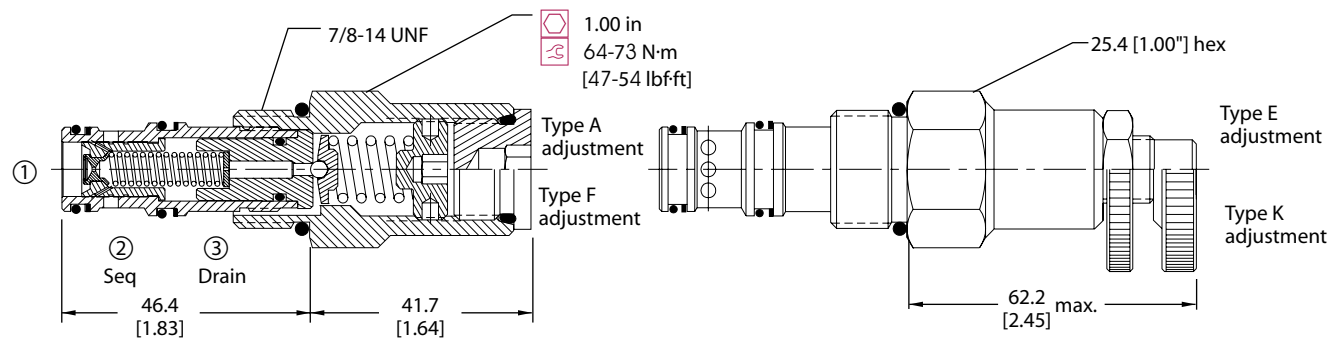

P102 174E

ORDERING INFORMATION

CP240 - 22 - B - 6S - A - C - 150

- Seals**
B = Buna-N
V = Viton
- Seal kit**
120027
120028
- Housing and ports**
0 = No Housing
SE3B = Al, 3/8 BSP
SE4B = Al, 1/2 BSP
6S = Al, #6 SAE
8S = Al, #8 SAE
Other housings available
- Housing P/N**
No Housing
SDC10-3-SE-3B
SDC10-3-SE-4B
CP10-3-6S
CP10-3-8S
- Adjustment option**
A = Internal
E = External
F = Tamper resistant
K = Knob
- Crack pressure**
Code x 10 = psi
Example: 150 = 1500 psi
- Pressure range**
A = 14-55 bar [200-800] [psi]
Standard 28 [400]
B = 21-103 [300-1500]
Standard 69 [1000]
C = 28-207 [400-3000]
Standard 103 [1500]
D = 28-345 [400-5000]
Standard 103 [1500]

P102 177E



Cartridge Valves Technical Information

Sequence valves

VDB 06-CN

OPERATION

This is a pilot-operated, atmospherically-vented, unloading valve.

SPECIFICATIONS

Theoretical performance

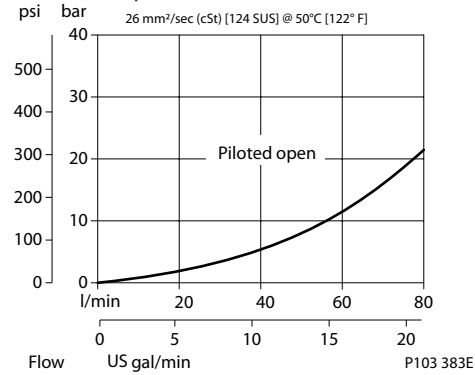

Schematic

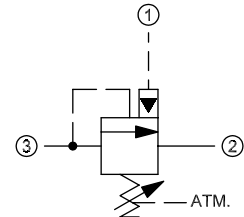

P103 523

Specifications

Rated pressure	350 bar [5000 psi]
Rated flow at 7 bar [100 psi]	80 l/min [21 US gal/min]
Weight	0.29 kg [0.64 lb]
Cavity	NCS06/3

DIMENSIONS

mm [in]

Cross-sectional view

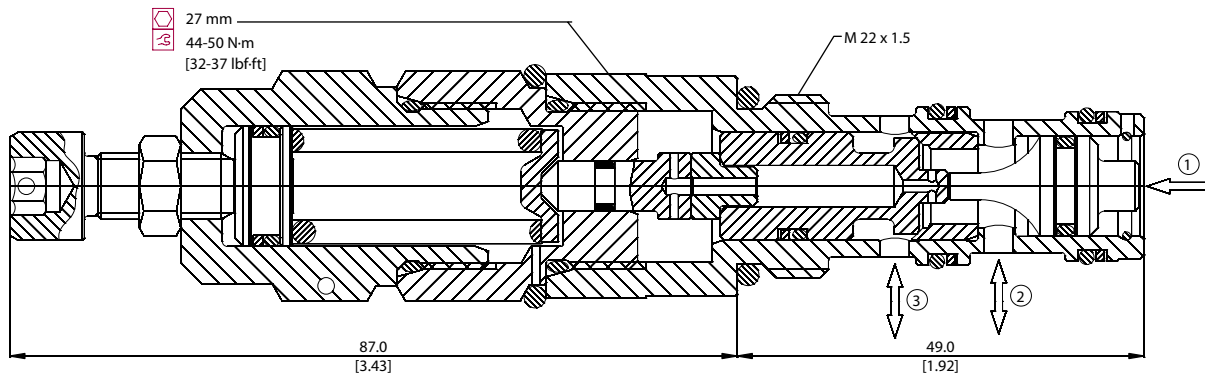

P103 407

ORDERING INFORMATION

VDB 06-CN - 2 - A - 00 - V

Setting range

- 1 = 25 - 140 bar [362 - 2031 psi]
- 2 = 70 - 210 bar [1015 - 3046 psi]
- 3 = 105 - 350 bar [1523 - 5076 psi]

Pilot ratio

- A = 7.1 : 1
- B = 4.1 : 1
- E = 1 : 1

Seals

- V = Viton
- Omit = Buna-N

Seal kit

- 230000110
- 230000070

Housing and ports

- 00 = No Housing
- SE3/8 = AL, 3/8 BSP
- SE1/2 = AL, 1/2 BSP
- SE6S = AL, #6 SAE
- SE8S = AL, #8 SAE
- Other housings available

Housing P/N

- No Housing
- NCS06/3-SE-3/8
- NCS06/3-SE-1/2
- NCS06/3-SE-6S
- NCS06/3-SE-8S

To order this valve with a specific factory setting, contact your Sauer-Danfoss representative

P103 408E



Cartridge Valves Technical Information
Sequence valves
Notes